

REPUBLIC OF AZERBAIJAN

On the rights of the manuscript

ABSTRACT

of the dissertation for the degree of Doctor of Philosophy

**WATER INTAKE FUNCTIONING WITH CONSTANT FLOW
RATE AT A VARIABLE HEAD IN A RESERVOIR**

Specialty: 3305.08 – «Hydrotechnical construction »

Field of science: Technique

Applicant: **Andrey Aleksandr Lipin**

Baku – 2025

The research work was performed at laboratory for the exploitation of ameliorative systems at Azerbaijan Scientific- Production Union of Hydraulic Structures and Amelioration.

Scientific Supervisor: doctor of technical science,
Sabir Tehranhan Hasanov

Official opponents: doctor of technical science,
Ahmed Shirin Mammedov

doctor of philosophy in technical,
assoc. prof., **Agamir Muslim Muslimov**

doctor of philosophy in technical
Rashad Saffan Abilov

One-time Dissertation Council BFD2.37 operating on the basis of the Dissertation Council FD2.37 of the Supreme Attestation Commission under the President of the Republic of Azerbaijan, Azerbaijan University of Architecture and Construction

Chairman of the one-time
Dissertation council:

Doctor of technical sciences, prof.
Mukhlis Ahmed Hajiyev

Scientific secretary of the
one-time Dissertation council:

Doctor of philosophy in technical,
assoc. prof., **Maarif Zabıt Yusifov**

Chairman of the One-time
scientific seminar:

Doctor of technical sciences, prof.
Bahram Huseyn Aliyev

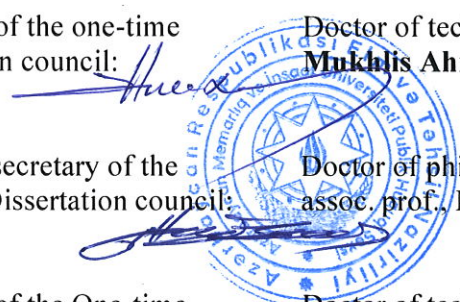
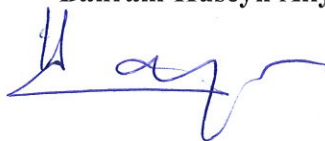

GENERAL DESCRIPTION OF WORK

Relevance of the topic and degree of development. The history of water management is nothing but the history of human race development. Water was not just a substance that supported life for people. First of all, it was the main element, essentially connected with all spheres of human activity.

Water intake structures are widely used in many areas of human activity: in agriculture, industry, water supply, irrigation, etc. Since ancient times, man has used water intake facilities to draw water from a source. Despite the variety of types and designs of water intake structures, they have their drawbacks. This led to need for the invention of a vertical telescopic water intake.

Vertical telescopic water intake allows for a constant flow when the water level in the water source changes. In addition to this, in non-channel reservoirs fed by the melt waters of mountain rivers, the temperature of the lower water layers is much lower than the upper ones. As a result of land irrigation with water from sources with low water temperatures adversely affect soil fertility and crop yields. Vertical telescopic water intake takes water from the upper layers heated by the sun's rays. This helps to improve the fertility of irrigated crops.

The first designs of vertical telescopic water intakes came in sight about 50 years ago. However, much less scientific works were devoted to the study of these water intakes comparing to other hydraulic structures. At the end of the 70s, the first proposal for the design of a vertical telescopic water intake was made in Japan. In the 80s, several more proposals appeared in Japan. In the early 90s, the works of S. T. Gasanov appeared, who proposed a new design for a vertical telescopic water intake, as well as its brief hydraulic calculation.

The disadvantages of existing designs of vertical telescopic water intake include the lack of solutions to increase stability resistance to external influences, the lack of devices that prevent debris from entering the intake tract, the lack of a device to stop water intake operation, the lack of a constructive solution for the energy dissipation

in the outlet tract when transporting liquid in an open way, by means of a channel. Also, the drawbacks of existing structures include technological shortcomings in terms of manufacturing and installation.

Object and subject of research. The object of research is a telescopic water intake. The subject of the study is to improve the design of a telescopic water intake and develop a methodology for its hydraulic calculation.

Purpose and main objectives of the research.

The aim of the work is to improve the design of a vertical telescopic water intake and develop a method for hydraulic calculation. In accordance with the aim, the following tasks should be solved in the work:

- Analysis of water intake structures and identification their shortcomings;
- Development of the design of telescopic water intake;
- Development of design solutions to improve the stability of the structure from external influences;
- Development of a device to prevent floating objects and debris from entering inside the water intake tract;
- Development of structural solution to stop water intake operation;
- Development of the design of a stilling well for energy dissipation of the flow in the downstream during the transportation of liquid in an open way, i.e. using a channel;
- Development of a method for hydraulic calculation of telescopic water intake;
- Development of a numerical model of telescopic water intake;
- Study of the critical immersion depth of water intake funnel and cavitation processes impact on the operation of a vertical telescopic water intake;
- Development of a methodology for hydraulic calculation of a stilling well;
- Development of a numerical model of a stilling well;

- Studying the scope of application of the improved design of vertical telescopic water intake;
- Justification of the economic efficiency of the improved design of vertical telescopic water intake.

Research method. To solve the assigned problems, literary, stock and project materials were analyzed and systematized. The shortcomings of existing designs of vertical telescopic water intake were identified and design solutions were proposed for their improvement. Using theoretical hydraulic data and computer modeling methods, a method for calculating vertical telescopic water intake was developed.

The main findings to be defended:

- New design solutions to increase stability of the structure from external influences;
- New structural solution for energy dissipation of the flow in the outlet tract when transporting liquid in an open way, i.e. by means of an open channel;
- New design solution for regulation of water intake operation;
- Methodology for hydraulic calculation of telescopic water intake;
- Methodology for hydraulic calculation of stilling well.

Scientific novelty. Scientific novelty of the results obtained in the dissertation is as follows:

1. Design solutions have been developed to increase stability of the structure from external influences.
2. Structural solution of stilling well has been developed.
3. Structural solution to stop water intake operation has been developed.
4. Methodology for hydraulic calculation of telescopic water intake has been developed.
5. Methodology for hydraulic calculation of stilling well has been developed.

Practical value. Practical value of the results obtained in the dissertation is as follows.

Design of the vertical telescopic water intake ensures its use on various types of water bodies: lakes, reservoirs, rivers, channels. Telescopic water intake allows the intake of water and liquids for various purposes: for domestic and drinking needs, for irrigation, for hydropower industry, for oil industry.

Telescopic water intake is effective for selective liquid intake. It can be used to draw warm layers of liquid or liquid of lower density from the surface.

Telescopic water intake is effective for use in reservoirs with suspended and bottom sediments, since it allows the intake of clarified water from the surface layers.

At the outlet of the telescopic water intake in the downstream, a sufficiently large kinetic energy is generated, which allows the connection of an electric generating turbine.

Personal contribution. All results submitted for defense were obtained personally by the author or with his direct participation. Statement of tasks, tasks solving methods, analysis and summary of dissertation results were carried out under supervision of supervisor Gasanov S. T.

Approbation of work. The main provisions and results of the dissertation work were reported by the author at scientific conferences in the republic and abroad: AzMİU “Tikinti istehsalatında texnoloji maşınların istifadəsinin müasir problemləri” Respublika Elmi – Praktiki Konfransı- 2019; scientific conference dedicated to the centenary of the faculty «Civil Engineering» Azerbaijan Architecture and Construction University - 2020; XXXV International Scientific and Practical Conference «Russian science in the modern world» - 2021; III International scientific conference « Priority directions of innovation activity in industry » - 2021.

The scientific novelty of the work was reviewed every year at the scientific and technical board of the Azerbaijan Scientific and Production Association «Hydrotechnic and Amelioration».

Publications. 18 scientific papers were published on the topic of the dissertation, 4 of these articles were published in foreign journals recommended by the Supreme Attestation Commission, and a patent of the Republic of Azerbaijan was obtained.

Structure and scope of work. The dissertation work consists of the introduction, five chapters, the main conclusions and the list of references. The total volume of work is 189 pages of typewritten text, including a list of sources from 202 items, 44 drawings and 4 tables. The dissertation, including the first chapter of 43 pages, the second chapter of 23 pages, the third chapter of 58 pages, the fourth chapter of 29 pages, the fifth chapter of 2 pages, has a total volume of 203 056 characters.

MAIN CONTENT OF THE WORK

Introduction. General characteristics of the work are given, its relevance is determined, the purpose of the dissertation and the tasks to be solved are formulated, the findings submitted for defense are determined, the scientific novelty and practical value of the research performed are justified.

Chapter I. Water intake facilities and their disadvantages. This chapter provides an analytical review of existing water intake facilities. Each of the existing designs of water intake structures was considered separately. Operating conditions and the quality of the water taken by water intakes of various designs were analyzed¹. In conclusion to the first chapter, it was found that the existing design of water intake structures is not perfect and their improvement is required. To solve this problem, design of a vertical telescopic water intake was developed.

Chapter II. Surface telescopic water intakes. This chapter is devoted to the analysis of existing designs of vertical telescopic water intake, identifying their shortcomings and developing design solutions for their improvement.

Description and operation principles of existing vertical telescopic water intakes are given. In the late 70s, the first application

¹ Липин, А.А. Водозаборные сооружения и их недостатки // -Баку: “AzHvəM” EİB-nin “Elmi Əsərlər Toplusu”, -2020. том XLI, -с. 275-279.

for the design of a vertical telescopic water intake was made in Japan. In the 80s, several more applications were issued in Japan. All these structures have the same disadvantages: the main disadvantage of this type of structures is their unsteadiness to anti-cavitation processes due to the discrepancy between the shape of the telescopic pipes and the shape of the flow, since with a vertical movement of the flow, the liquid acquires a shape that narrows to the bottom, and the movable pipes have a shape that expands to the bottom, therefore, a vacuum is formed in the converging part of the flow due to which cavitation occurs and the flow is separated from the pipe wall, which entails vibration of the devices, the need to use anti-cavitation devices, the structures have a complex structure, there is no element preventing the ingress of floating objects into the water intake structure, there is no device for stopping water intake operation.

In order to eliminate the shortcomings of known water intakes, increase their efficiency and simplify the design, in 1991 the design of a telescopic water intake was proposed by Gasanov S.T.

Developed telescopic water intake contains a float, an inlet funnel, telescopically connected pipes tapering downwards, an elbow with a discharge pipeline and connecting elements. In order to prevent cavitation, an air supply cone-shaped pipe with a protrusion directed towards the inlet funnel is installed in the middle part of the float. To ensure automated movement of the float down until the inlet funnel is closed in the absence of water (or liquid) or when the dead volume of water in the source is reached, springs are installed in the lower part of the connecting elements (Picture 1).

The float, holding the inlet funnel submerged in water, providing a constant pressure at its inlet. In this case, water from the upper layers enters the funnel, and from there into the telescopically connected pipes, and then through the knee into the outlet pipeline.

When the water level in the source decreases, telescopically connected pipes, funnel and float go down, and when the water level

rises, they rise up. Due to this, automated water intake and the constancy of its flow rate are ensured, regardless of the current level in the source. Water intake is carried out from the upper horizons, therefore, more clarified, clean and at the same time warmer water, heated by direct sunlight, enters into the water intake.

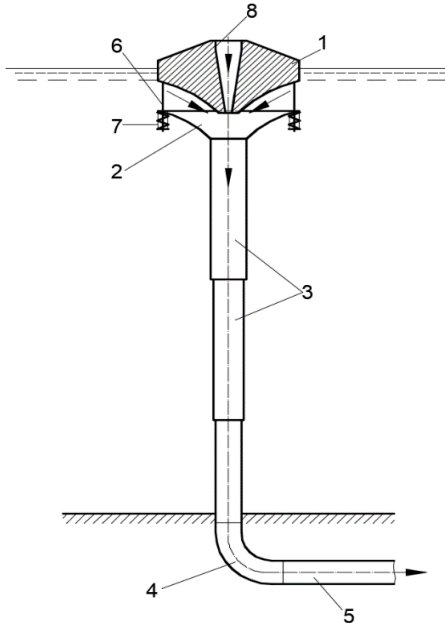

Picture 1. Structure of telescopic water intake:
1-float, 2-intake funnel, 3-telescopically connected pipes, 4-elbow, 5- discharge pipeline, 6-connecting elements, 7- spring, 8- air supply confuser.

In case of water absence or reaching the dead volume in the source, the springs installed under the connecting elements provide automatic closing of the inlet funnel.

Proposed device has high mobility, a wide range of applications, is very simple and convenient in operation compared to known ones.

Despite these advantages of water intake, it has a number of disadvantages. Telescopic water intake, used in large reservoirs, rivers with high flow velocities, navigable channels, and so on, is not very resistant to external influences. The point is that, under the influence of external forces and factors, for example, during storms, storm waves, hurricanes, ice drifts, strong currents and winds, as well as other adverse situations, the device can overturn and destroy, since all

its elements are held by the knee. Excising device does not provide an element to stop water intake in emergency situations, a stilling well for energy dissipation in the downstream and a protective element to prevent floating and foreign objects from entering the inlet funnel, and then into the water intake. In addition, there is no specific method for calculating telescopic water intake.

Solutions are proposed to improve the design of a vertical telescopic water intake. To increase stability of the water intake to external influences, piles with guide slots are installed around the float, “T” shaped protrusions are installed on the edge of the float, which are placed in the guide slots of the piles. Such a connection of the float with piles allows to ensure the strength and at the same time the stability of the entire water intake structure (Picture 2.). Since all elements are firmly connected to each other, when an external influence occurs, they manifest themselves as connected supports^{2,3}.

To prevent foreign floating objects from entering inside the water intake, a cylindrical removable protective grille is installed around the connecting elements on the inlet funnel. To stop or regulate the flow of water taken from the source, a gate (valve) is installed on the outlet pipeline in the downstream, and a stilling well is built behind it to dissipate the energy of water and prevent local erosion (Picture 2.). If the water intake is intended for water supply and transportation is carried out over long distances using a pipeline, then in this case there is no need for a water well^{4,5}.

During operation of a telescopic water intake, a sufficiently high working pressure is formed at the outlet of the outlet pipeline, thus kinetic energy, which can be used to generate electrical energy by

²Гасанов, С.Т. Устройство для забора воды, İxtira a2020 0073, Азербайджанская Республика / Гасанов С.Т., Липин А.А. -2022.

³ Гасанов, С.Т. Усовершенствование конструкции и повышение устойчивости телескопического водозабора / С.Т.Гасанов, А.А.Липин. // Гидротехническое Строительство, -Москва: -2021. № 4, -с. 58-63.

⁴ Липин, А.А. Телескопический водозабор с водобойным колодцем// -Баку: “AzHvəM” EİB-nin “Elmi Əsərlər Toplusu”, -2021. том XLI, -с. 223-231.

⁵ Lipin, A.A. Telescopic water intake with stilling well // -Moscow: Magazine of Civil Engineering, -2022. Article No 11209, -p. 1-8.

installing a reactive electric turbine on the line at any convenient place in the outlet pipeline.

To regulate water intake operation, it is necessary to provide a device for stopping water intake in the structure of vertical telescopic water intake. The most effective way to stop water intake is to put a float on the intake funnel.

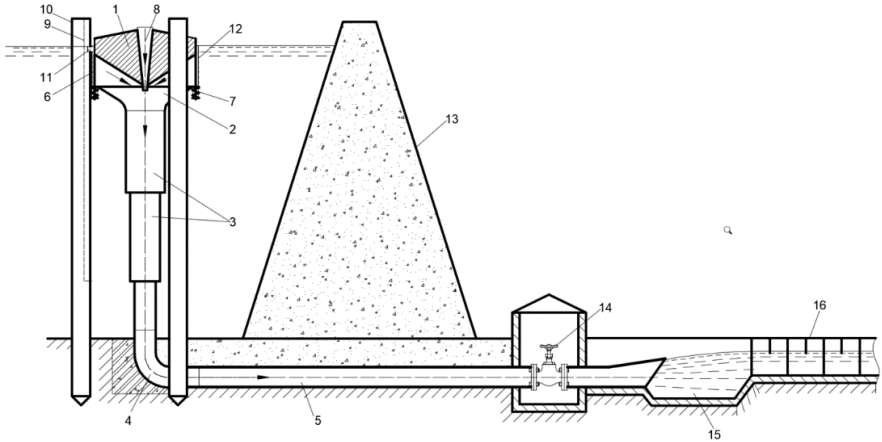

Picture 2. Scheme of telescopic water intake:

1-float; 2-intake funnel; 3-telescopically connected pipes; 4-elbow; 5- outlet pipeline; 6-conecting element; 7- springs; 8- air supply confuser; 9- guide slot; 10- pile; 11- T-shape protrusion; 12- grid; 13-dam; 14- gate; 15-stilling well; 16- channel.

Suggested structural solution allows to stop water intake operation. To place the float (1) on the funnel (2) (Picture 3.) it is possible to give the telescopic column positive buoyancy. Then the water intake funnel will rise to the level of the float and come into contact with it, while a tight connection is formed between them, preventing water from entering the funnel. Positive buoyancy of the telescopic column can be provided by installation of additional pontoon.

To raise the intake funnel up, the pontoon should be blown off with air. When filling the pontoon with air, water will be removed

through the holes in the bottom of the pontoon. Air supply to the pontoon can be done with an air compressor or compressed air tanks, which can be placed on the top of the dam or on the shore. To blow off the pontoon, depending on the size of water intake structure, a pressure of 0.6-1 MPa will be required. The compressor can be connected to the ballast pontoon using a reinforced hose or flexible plastic pipe. There is a wide range of air compressors in the market with this operating pressures powered electrically or by diesel. Balloons with compressed air should be connected to the line through a gas reducer to reduce the pressure of air leaving the balloon to the required value.

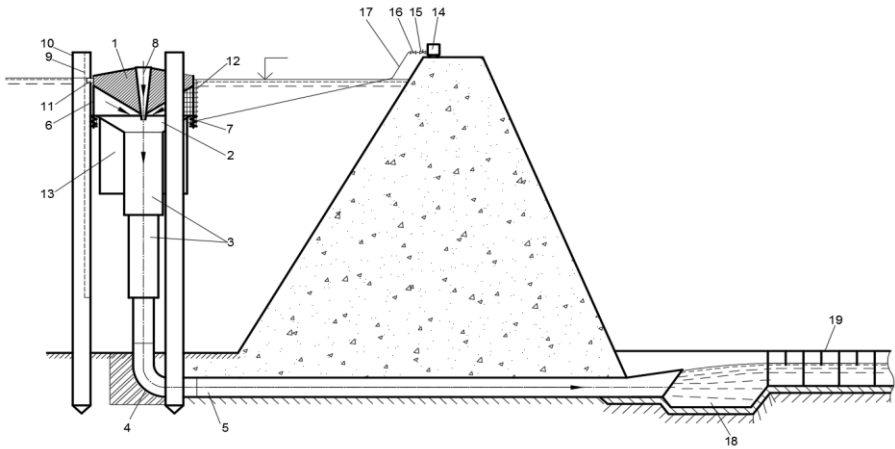

Picture 3. The design of telescopic water intake equipped with a ballast pontoon: 1 - float, 2 - funnel, 3 - telescopic pipeline, 4 - elbow, 5 - outlet pipeline, 6 - connecting elements, 7 - release springs, 8 - air supply confuser, 9 - guide slots, 10 - piles, 11 - T-shaped ledge, 12 - protective grid, 13 - ballast pontoon, 14 - compressor, 15 - pressure reducing valve, 16 - air release valve, 17 - hose, 18 - stilling well, 19 - channel.

To resume water supply, lower the intake funnel to the design position. By turning off the compressor and opening the non-return valve, the water will force the air out of the pontoon and it will fill with water. In this case, the intake funnel together with the telescopic

column will move down under its own weight. When calculating the buoyancy of the float (1), in addition to the weight of the intake funnel and the telescopic pipe column, the weight of the ballast pontoon should also be taken into account. This system can be controlled both manually and remotely using a radio signal.

Chapter III. Hydraulic calculation. This chapter of the dissertation is devoted to the development of a methodology for hydraulic calculation of a vertical telescopic water intake, the development of a methodology for the hydraulic calculation of a waterworks structure, computer modeling of hydraulic processes and analysis of the results obtained.

Hydraulic calculation of vertical telescopic water intake consists in calculating the following elements:

- funnel
- telescopic column
- float
- elbow
- discharge pipeline
- stilling well

The calculation of water intake is carried out in the following sequence. First, the immersion depth of the inlet funnel is determined. Traditionally, specialists involved in the design of surface water intakes have faced the problem of vortex formation. Based on the analysis of literary materials and computer models, a formula was obtained for determining the critical depth of immersion, at which vortex formation is insignificant and does not have a serious impact on the structure^{6,7}:

$$H = 1,5D_g, \quad (1)$$

where H-head of the funnel crest, m; D - inlet diameter of the funnel, m.

⁶Липин, А.А. О моделировании свободной поверхности потока в поверхностных водозаборах используя метод конечных элементов // -Баку: AzMIU Elmi Əsərlər, - 2020. № 1, -с. 105-111.

⁷ Гасанов, С.Т. Усовершенствование конструкции и повышение устойчивости телескопического водозабора / С.Т.Гасанов, А.А.Липин. // Гидротехническое Строительство, -Москва: -2021. № 4, -с. 58-63.

The main parameters for designing a vertical telescopic water intake funnel are the inlet diameter of the water intake funnel D and the pressure on the crest of the funnel H . Using these parameters as well as μ flow coefficient, the capacity of the funnel can be determined by the following formula:

$$Q = \mu \frac{\pi \cdot D^2}{4} \sqrt{2gH}, \quad (2)$$

where D - funnel inlet diameter, m; Q - intake water consumption, m³/s; μ - flow coefficient; H - head of the funnel crest, m; $g=9,81$ – acceleration of gravity, m/s²; $\pi=3,14$ – constant characterizing the ratio of circumference to diameter.

Based on the analysis of a large number of computer models and analytical calculations, the optimal value of the flow coefficient was obtained $\mu = 0,30-0,45$.

Note down that the flow rate Q , taken from the source is defined by the consumption. To connect the inlet funnel with a float behind the crest of the funnel, an initial section with a length of $L= (0,4-0,5) D$ to be arranged. In this case, the funnel diameter, taking into account the length of the initial section, is determined by the formula:

$$D_{\text{opt}} = D + 2L, \quad (3)$$

To determine the diameter of the outlet part of the funnel, its height is taken equal to the diameter of the inlet part of the funnel, i.e. $h_e=D$, then the diameter of the outlet part of the funnel is determined by formula:

$$d_{\text{out}} = \sqrt{\frac{4Q}{\varphi\pi\sqrt{2g(H+h_e)}}}, \quad (4)$$

where d_{out} – funnel outlet diameter, m; Q - water consumption, m³/s; φ – velocity coefficient (accept $\varphi=0,96$ to calculate and study the hydraulic model); H - pressure on the crest of the funnel, m; h_e – pressure, counting from the cavity of the outlet part of the funnel to its crest, m.

The mode of flow movement in the telescopic column is assumed to be pressure mode, i.e. pipes work with a full section.

Diameter of the first telescopically connected pipe is assumed to be equal to the diameter of the outlet part of the funnel, i.e. $d_1 = d_{\text{вых}}$.

Second pipe diameter (d_2), determined by equation:

$$d_2 = d_1 - 2(\delta + a), \quad (5)$$

where d_1 - inner diameter of the first pipe, m; δ - second pipe wall thickness, mm; a - gap between pipe walls or support ring thickness, mm.

Diameter of following pipes is determined by the dependence (5), according to the diameter of the previous pipe and the wall thickness, for example, the diameter of the third pipe is determined as follows: $d_3 = d_2 - 2(\delta + a)$.

Diameter of the elbow and the outlet pipeline is assumed to be equal to the diameter of the last pipe, i.e. $d_{\text{кол}} = d_{\text{нос}} = d_{\text{тпр.п}}$. The last pipe is connected to the elbow and is considered fixed.

To combat cavitation processes, it is necessary to increase the radius of curvature of the elbow. According to the recommendations available in the literature, the curvature radius should be assigned $R_0 = 2.5d_{\text{кол}}$. Based on the analysis of the hydraulic regime in the elbow using computer models, the optimal radius of curvature was obtained to prevent cavitation processes⁸:

$$R_0 = 2.5d_{\text{кол}}, \quad (6)$$

Calculation of the float is to establish buoyancy, i.e. its performance, taking into account the load imposed on it, and thus, in determining the depth of immersion, height and diameter of the float. The buoyancy of the float is set according to the theory of floating bodies, i.e. according to the law of Archimedes.

⁸Липин, А.А., Об определение потери давления в изогнутых частях телескопического водозабора // AzMİU “Tikinti istehsalatında texnoloji maşınların istifadəsinin müasir problemləri” Respublika Elmi –Praktiki Konfransı, - Баку: -2019, -с. 220-223.

According to this law, to ensure the buoyancy of the float, the lifting force P_f is equal to the force G , tending to immerse it in water.

$$P_f = G, \quad (7)$$

Lifting force (kg, ton, or kN) determined by equation:

$$P_f = \gamma \omega h = \gamma W, \quad (8)$$

where $\gamma = \rho g$ – volumetric weight of water, kg/m^3 ; ω – cross-sectional area of the float limited by the wetting contour m^2 ; h – draft of the float, m; W – the volume of water displaced by the float or volumetric displacement, m^3 ; ρ – density of water, kg/m^3 .

The force tending to submerge the float in water (G) includes the weight of the float itself, funnel, telescopically connected pipes (hanging pipes) and other elements of the device. The weight of each element is determined by the formula known in physics:

$$G_i = \sum \rho_i W_i = \sum \rho_i S_i \delta_i; \quad (i=1, 2, \dots, n), \quad (9)$$

where ρ – density of the material from which the element is made, kg/m^3 ; W_i – volume of material, m^3 ; S_i – element surface area, m^2 ; δ_i – material wall thickness, m.

Equation (7), taking into account (8) and (9), has the form:

$$\gamma W = \sum G_i, \quad (10)$$

By means of equation (10), the buoyancy of the float is established, and the dimensions of it are also determined.

Displacement is determined by the shape of the float. In a specific case, according to the equation:

$$W = \frac{1}{3} h_1 \omega + h \omega, \quad (11)$$

where h_1 – height of the conical part of the float, completely submerged in water, m; $\omega = \pi D_{non}^2 / 4$ – sectional area of the cylindrical part of the float, m^2 ; D_{float} – float diameter, m; h – immersion depth of the cylindrical part of the float, m.

If the load acting on the float is defined, from equality (10) the displacement is determined:

$$W = \frac{\sum G_i}{\gamma}, \quad (12)$$

With a known value of the displacement W and the diameter of the float D_{float} from equation (11), the depth of immersion of the cylindrical part of the float is determined:

$$h = \frac{W}{\omega} + \frac{1}{3} h_1, \quad (13)$$

Draft - the total depth of immersion of the float is determined by the sum of the immersion depths of the conical h_1 and cylindrical parts h (Picture 2.):

$$h_{total} = h_1 + h, \quad (14)$$

It should be noted that the calculation of the float is carried out by the approximation method, since the dimensions and the weight of the float are not known. Therefore, in the first approximation, the height (t_{float}) of the cylindrical part of the float is taken, and then its weight is calculated. If during the calculation the accepted float height turns out to be less or significantly greater than the calculated one, then in this case its value is increased or decreased and the calculation is performed again.

The calculation of the float can be done differently, for example, by taking (setting) the immersion depth to determine its diameter. This approach to solving the problem is more complex. In a specific case, the buoyancy or performance of the float is checked by the equation:

$$\gamma \left(\frac{1}{3} h_1 + h \right) \frac{\pi D_{non}^2}{4} = \sum G_i, \quad (15)$$

where all symbols are the same.

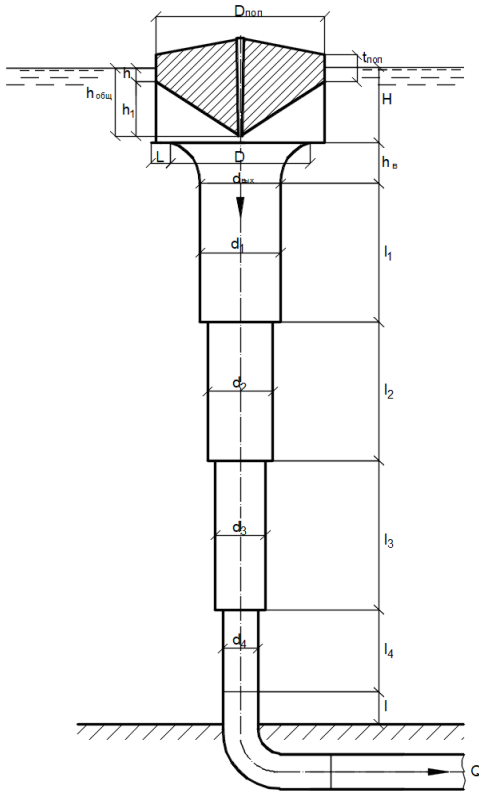

Picture 4. Scheme for the calculation of telescopic water intake.

Numerical modelling. Numerical modeling of hydraulic processes in a vertical telescopic water intake is being carried out. Modeling was performed in three versions.

Comparing water velocity diagram of three models no vortex formation was observed at the funnel crest. No significant cavitation was observed on the funnel walls. The shape of the funnel, obtained by analytical calculation, using the flow rate $\mu = 0.36$, enables avoiding active cavitation on the walls of the funnel. The immersion depth of the funnel crest, calculated according to the formula (1), provides a normal hydraulic regime without the formation of vortex flows. Hence, long service life and normal operation of the funnel are ensured.

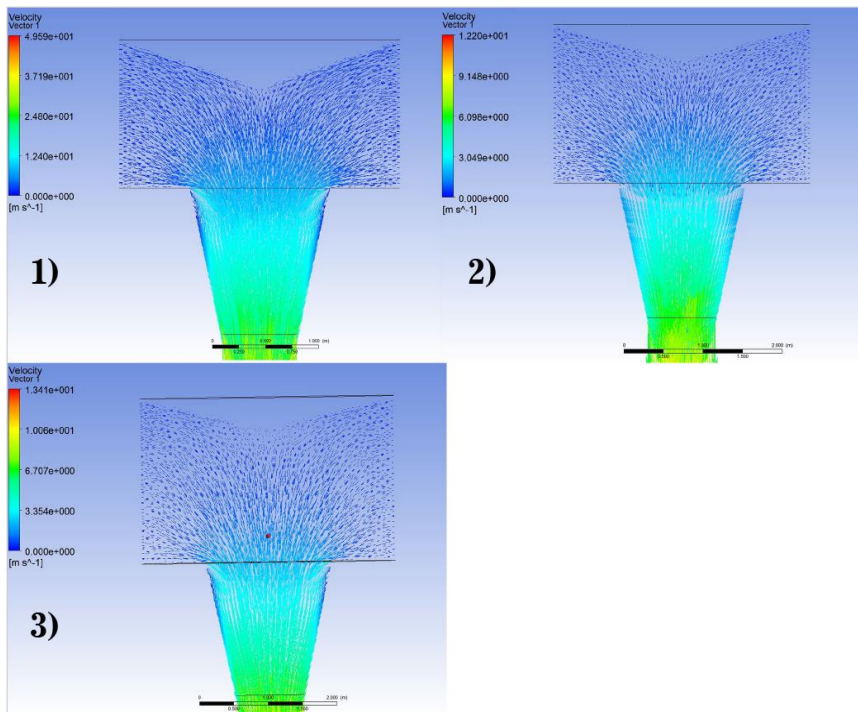

Picture 5. Diagram of velocities distribution in the longitudinal section of the funnel: 1 - example 1; 2 - example 2; 3- example 3.

Comparing results of three models (Picture 5.) no vortex formation was observed at the funnel crest. No significant cavitation was observed on the funnel walls. The shape of the funnel, which was obtained by analytical calculations, using the flow rate coefficient $\mu = 0.36$, and $h_{\text{fun}}=D$ dimension ratio, enabled avoiding formation of vortex at the immersion depth calculated according to formula (1). The shape of the funnel enabled avoiding active cavitation on the walls of the funnel. Hence, a long service life and normal operation of the funnel are ensured.

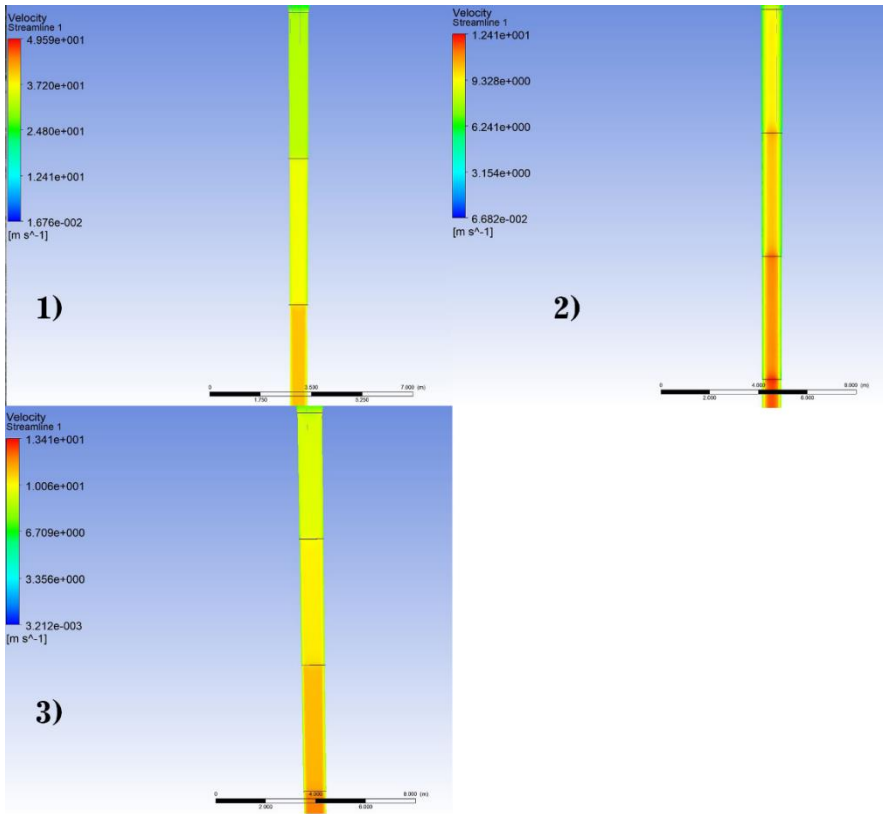

Picture 6. Diagram of water velocities distribution in the longitudinal section of the telescopic column: 1 - example 1; 2 - example 2; 3- example 3.

We observed flow separation at the elbow. In spite of higher velocities near the convex surface than those near the concave surface, active cavitation processes and vortex formation were not observed in the elbow. (Picture 7.). Curvature radius determined by the formula (6) avoids the formation of active cavitation without the implementation of additional structural solutions. At the same time, calculation of the curvature radius by means of equation (6) allows keeping dimensions of the elbow compact.

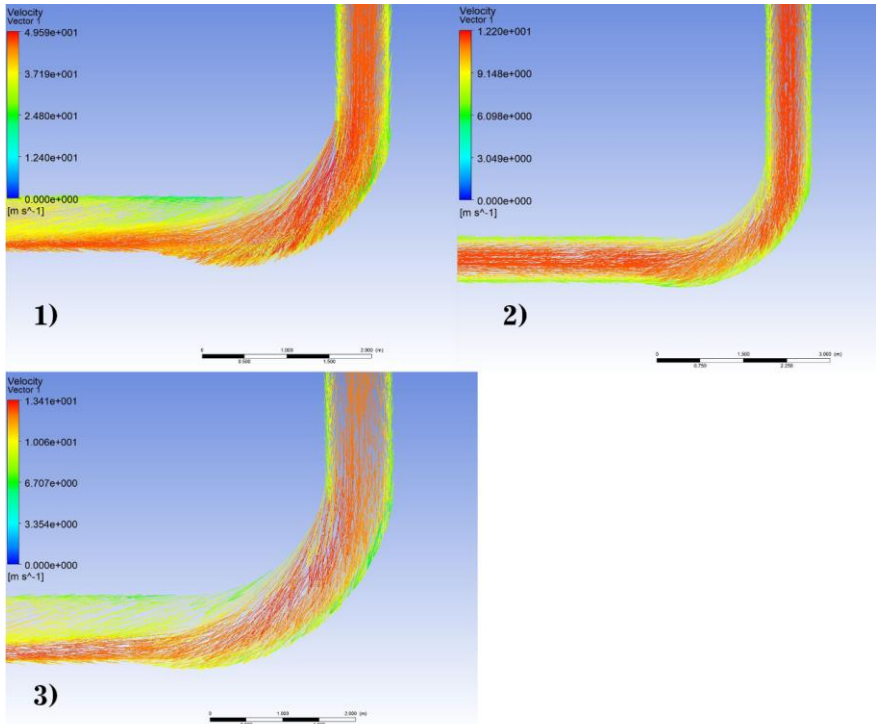

Picture 7. Diagram of water velocities distribution in the longitudinal section of the elbow: 1 - example 1; 2 - example 2; 3- example 3.

Calculation of a stilling well. Methodology for calculating a water well was developed.

The calculation of the stilling well is performed as follows. The water leaving the vertical telescopic water intake into the open channel at the outlet is compressed and then expanded. Water leaving the vertical telescopic water intake into the open channel at the outlet expands. The water leaving the diffuser gradually expands and at the end of the jet's flight reaches its maximum value. The jet expansion angle (θ_g) is equal to the diffuser taper angle (θ_d).

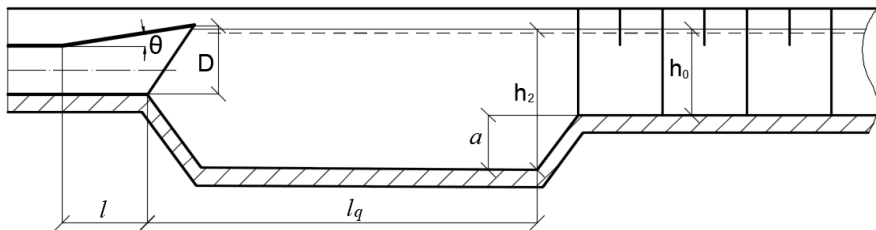

Picture 8. Scheme for calculation of stilling well.

The diameter obtained at the end of the jet's flight can be taken as the depth of the water in the stilling well. In general, it is determined by the conjugate depth of the transporting channel:

$$a = h_2 - h_b, \quad (16)$$

where a is the depth of the stilling well (m); h_2 is conjugate depth (m); h_b is depth of water in the channel (m).

Conjugate depth depending on the expansion angle (θ) is determined as:

$$h_2 = D + 2 L \operatorname{tg} \frac{\theta}{2}, \quad (17)$$

where D – diffuser outlet diameter, m ; θ – diffuser or jet expansion angle, degree; L – jet flight length, m.

The flight length of the jet leaving the diffuser (L) in hydraulics is determined depending on the speed and acceleration of free fall according to the following equation:

$$L = v \sqrt{\frac{2(Z + 0,5D)}{g}}, \quad (18)$$

where v is the speed of the jet leaving the diffuser, m/s; Z is the difference between the upstream and downstream pressures m; D is diameter at the outlet of the diffuser, m; $g = 9.81 \text{ m/s}^2$ is acceleration of gravity.

The velocity of the jet leaving the diffuser (v) is calculated using the following formula:

$$v = \frac{Q}{\omega} = \frac{4Q}{\pi D^2}, \quad (19)$$

where Q – is the water intake flow rate, m³/s; $\omega = \pi D^2 / 4$ is area of the outlet part of the diffuser, m².

The length of the waterworks is determined only by the length of the jet flight. Therefore, the length of the jet flight determined by formula (18) is taken as the length of the stilling well.

Numerical modeling of stilling well. Numerical modeling of a stilling well is carried out⁹.

Based on the results of the calculation, the average speed at the exit from the channel was 1.26 m/s.

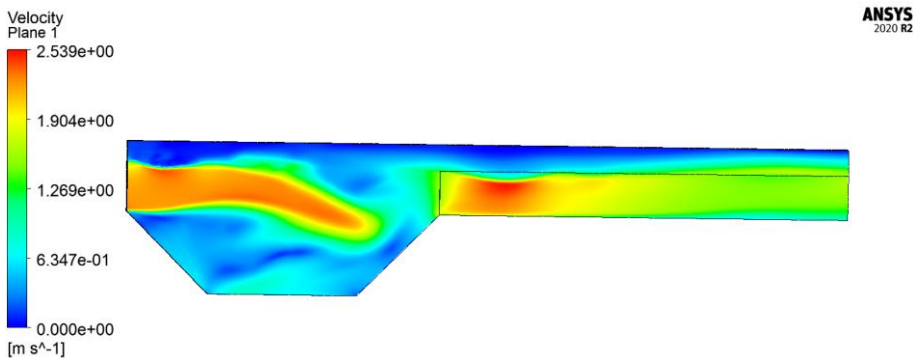

Picture 9. Diagram of water velocities distribution in the longitudinal section of a stilling well.

It should be noted that when modeling a stilling well together with a channel, the formation of a hydraulic jump at the entrance to the channel is visible (Picture 9.). Due to the hydraulic jump, the speeds at the inlet section in the channel increase to 2.25 m/s. Taking into account such an increase in speeds, we recommend reinforcing

⁹Lipin, A.A. Telescopic water intake with stilling well // -Moscow: Magazine of Civil Engineering, -2022. Article No 11209, -p. 1-8.

the bottom of the channel in the initial section, equal to the length of the water well.

Analytical calculation of additional ballast pontoon.

Calculation of additional ballast pontoon consists in defining buoyancy i.e. its functionality, taking into account the load imposed on it and thereby determining the height and diameter of the additional pontoon. The buoyancy of the pontoon is determined according to the theory of floating bodies; i.e. according to Archimedes' law.

According to this law, to ensure the buoyancy of ballast pontoon, the lifting force P_b is equal to the force G , which tends to submerge it in water:

$$P_b = G - F_A, \quad (20)$$

where $F_A = g\rho_w V_{st}$ – Archimedes force, kN; g - acceleration of gravity, m/s^2 ; ρ_w - density of water, kg/m^3 ; V_{st} – volume of the structure including volume of pontoon itself, funnel, telescopically connected pipes (suspended pipes) and other elements of the device, m^3 .

Lifting force (kN) is determined by the formula:

$$P_b = \gamma\omega_p h_p = \gamma W, \quad (21)$$

where $\gamma = \rho_w g$ - the volumetric weight of water, kN/m^3 ; ω_p - cross-sectional area of the pontoon, limited by the contour of wetting, m^2 ; h_p - pontoon height, m ; W - volume of water displaced by the pontoon or volumetric displacement, m^3 .

The force trying to immerse the float in water (G) includes the weight of pontoon itself, funnel, telescopically connected pipes (suspended pipes) and other elements of the device. The weight of each element is determined by the formula known in physics:

$$G_i = g \sum \rho_i W_i = g \sum \rho_i S_i \delta_i; \quad (i=1, 2, \dots, n), \quad (22)$$

where ρ_i - density of material from which the element is made, kg/m^3 ; W_i - volume of material, m^3 ; S_i - element surface area, m^2 ; δ_i - material wall thickness, m .

Equation (20) taking into account (21) and (22) has the following form:

$$\gamma W = \sum G_i - F_A, \quad (23)$$

Buoyancy, or working capacity of the pontoon, and the dimensions of it are determined by means of equation (23).

The displacement is determined by the shape of the pontoon. In this specific case:

$$W = h_p \omega_p, \quad (24)$$

where h_p - pontoon height, m; $\omega_p = \pi \frac{d_p^2 - d_1^2}{4}$ - pontoon cross-sectional area, m²; d_p - pontoon diameter, m; d_1 - diameter of the first pipe section, m.

If the load acting on the pontoon is defined, the displacement is determined by equation (23):

$$W = \frac{\sum G_i - F_A}{\gamma}, \quad (25)$$

With the known value of displacement W and the diameter of the pontoon d_p , the height of the cylindrical pontoon is determined by equation (24):

$$h_p = \frac{W}{\omega_p}, \quad (26)$$

It should be noted that the calculation of the ballast pontoon is carried out by the approximation method, since the dimensions and, subsequently, the weight of the pontoon are not known. Therefore, in the first approximation, height of the pontoon (h_p) is accepted, and then its weight is calculated. If in the process of calculation the accepted height of the pontoon turns out to be less or significantly more than the calculated one, then in this case its value should be increased or decreased and the calculation to be performed again.

Calculation of the pontoon can be carried out in another way, for example, taking (accepting) the height of the pontoon, you can determine its diameter.

$$\gamma h_p \pi \frac{d_p^2 - d_1^2}{4} \geq \sum G_i, \quad (27)$$

where all symbols are the same.

When intake of water is stopped, the water will go out of the structure and the structure will be filled with air. In this case telescopic column together with funnel will acquire positive buoyancy. In order to start water intake operation again we should check following equation:

$$G - F_A \geq P_{st}, \quad (28)$$

where P_{st} - buoyancy of telescopic column and funnel in the top position.

Buoyancy force trying to keep structure afloat includes the buoyancy of funnel and telescopically connected pipes:

$$P_{st} = \gamma \sum W_{st.i}, \quad (29)$$

where $W_{st.i}$ - volumetric displacement of element.

Fluctuations of the water surface. The analysis of the influence of water surface fluctuations on the operation of a vertical telescopic water intake was carried out.

Chapter IV. This chapter is devoted to the analysis of the scope and conditions of application of the improved design of vertical telescopic water intake.

Water quality. The quality of water in the sources of water supply is analyzed.

Water transparency. The transparency of water in the sources of water supply is analyzed.

Turbidity of water. The turbidity of water in water supply sources is analyzed.

Mineral composition of water. The mineral composition of water in water supply sources is analyzed.

Scope of use. Expansion of the scope of the improved telescopic water intake is being considered.

Taking into account the peculiarities of water intake from the reservoir, the use of a surface water intake of a telescopic type is effective when combined with the dam's hydroelectric complex or separately, provided that the optimal depth for its operation is ensured¹⁰.

The principle of operation of a vertical telescopic water intake in the main canal is similar to its operation in a river. This structural solution will effectively take water from the canal.

The application of an improved design of a vertical telescopic water intake is analyzed, taking into account economic needs¹¹.

Telescopic water intake has a number of advantages. It allows a constant intake of water from the upper layers of the water column, free from sediments, and at the same time provide a constant flow. Thus, the quality of the water taken in increases, and the process of its purification is simplified.

Taking into account the peculiarities of the temperature regime in reservoirs, it becomes obvious that the upper layers of the water column have the highest temperature. Increasing the temperature of irrigation water contributes to an increase in crop yields. And vice versa, when the temperature drops below 20⁰C, the crop yield decreases by 30-40%, and when the temperature drops below 15⁰C, crops die completely. Therefore, water intake from the upper layers will increase the yield. To take water from the surface layers, it is recommended to use a vertical, telescopic water intake. The use of this type of water intake will significantly increase the efficiency of irrigation.

¹⁰ Lipin, A.A. Surface telescopic water intake: A review // -Moscow: Alfa Built, -2020. № 3 Volume 15, Article No 1502, -p. 1-7.

¹¹ Липин, А.А. Применение вертикального телескопического водозабора с учетом хозяйственных нужд // -Баку: Наука и Мир, -2020. № 4 (80) Vol. I, -с. 33-36.

Considering the principle of gravitational settling, the use of an improved design of a vertical telescopic water intake will be effective for oil dehydration. Operation principle of a telescopic water intake is based on the intake of liquid from the upper layers. In this case, oil separated from water will be taken from the upper layers (Picture 10.). Water and solids, having a density higher than that of oil, will settle to the bottom of the sump. The advantage of the design of a vertical telescopic water intake is that it will ensure continuous oil intake from the upper layers when the pressure in the sump changes¹².

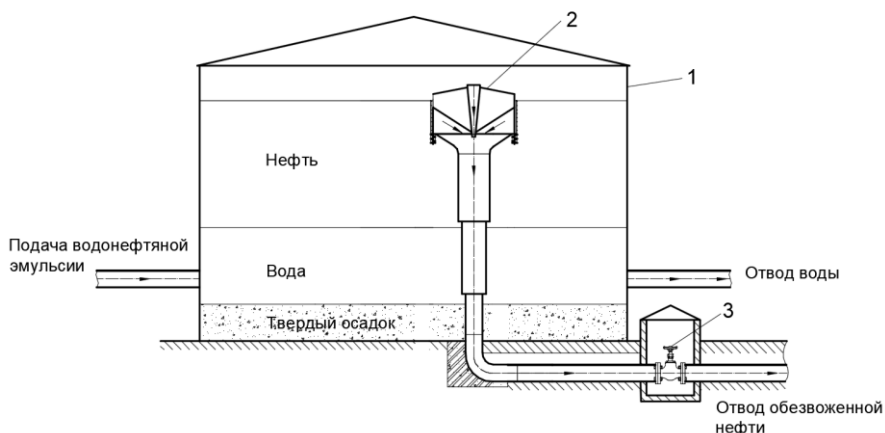

Picture 10. Dehydrated oil intake by telescopic water intake:
1- settling tank, 2- telescopic water intake, 3-gate.

Appointment in the hydro-complex. The purpose of the vertical telescopic water intake in the hydroelectric complex is determined.

The design of the vertical telescopic water intake can be adjusted in such a way that water intake will be carried out after passing a certain level in the reservoir.

¹² Липин, А.А., Сепарация нефти с помощью телескопического водозабора // III Международная научная конференция «Приоритетные направления инновационной деятельности в промышленности», -Баку: -2021, -с. 75-78.

Chapter V. Economic efficiency of telescopic water intake.

This chapter is devoted to the rationale for the economic efficiency of an improved vertical telescopic water intake.

To calculate the economic efficiency of using the enhanced design of a vertical telescopic water intake compared to a base device, the base device considered in reference is a tubular water intake. The design of this structure is the closest to that of a telescopic water intake.

The economic efficiency of application of the vertical telescopic water intake compared to the base device can be evaluated based on the ratio of the difference in operational costs over the period of its use to the difference in construction costs of one unit. The formula for calculating economic efficiency is as follows:

$$\varepsilon = \frac{C_{\Delta}}{H} \quad (30)$$

where C_{Δ} - the difference in operational costs between the base device and the vertical telescopic water intake over its period of use (e.g., 10 years); H - the difference in estimated cost between the base device and the vertical telescopic water intake.

Based on the project documentation, the estimated cost and operational expenses of the base water intake device allow us to assess the economic efficiency of the vertical telescopic water intake compared to the base model. The estimated cost of the base device ranges from 133,000 to 1.9 million manats. For specific calculations, the average cost of 1 million manats is used. The operational expenses of the base device average between 13,300 and 190,000 manats per year. For assessment purposes, the average expense of 100,000 manats per year is used.

Vertical telescopic water intake has an estimated cost ranging from 5,700 to 1.425 million manats. For specific calculations, we consider 650,000 manats per year. Due to more efficient operation, operational costs can be reduced from 0.57 thousand to 142.5 thousand manats. For assessment, average costs of 80,000 manats will be used.

$$C_{\Delta} = (100000 - 80000)10 = 200000 \text{ manats};$$

$$H = 1000000 - 650000 = 350000 \text{ manats};$$

$$\Theta\Theta = \frac{200000}{350000} = 0,57 \text{ or } 57\%$$

From this calculation, it is clear that there are savings in financial resources during the construction and operation of the vertical telescopic water intake. Therefore, it can be concluded that the enhanced design of the vertical telescopic water intake is economically efficient.

Publications

1. Lipin, A.A. Influence of water fluctuations on the operation of surface water intake // Journal of Ecology and Water Management. -2019. No. 3, -p. 51-56.
2. Lipin, A.A. Analysis of the formation of eddy funnels in a vertical water intake // Journal of Ecology and Water Management; -2019. No. 3, -p. 67-72.
3. Lipin, A.A. On the determination of pressure loss in the curved parts of a telescopic water intake // AzMIU “Tikinti istehsalatında texnoloji maşınların istifadəsinin müasir problemləri” Respublika Elmi – Praktiki Konfransı- 2019. -p. 220-223.
4. Lipin, A.A. Water intake facilities and their shortcomings // “AzHvəM” EİB-nin “Elmi Əsərlər Toplusu”, - Baku, volume XLI, -2020. -With. 275-279.
5. Lipin, A.A. On modeling the free surface of the flow in surface water intakes using the finite element method // AzMIU Elmi Əsərlər - 2020. No. 1, -p. 105-111.
6. Lipin, A.A. Directions and areas of application of vertical telescopic water intake // journal AZMIU Elmi Əsərlər -2020. No. 2, -p. 76-82.
7. Lipin, A.A. The use of vertical telescopic water intake taking into account economic needs // Journal of Science and the World - 2020, No. 4 (80) Vol. I; -With. 33-36.
8. Lipin, A.A. Surface telescopic water intake: A review // journal Alfa Built - 2020. No. 3 Volume 15, Article No 1502, -p. 1-7.
9. Lipin, A.A. Influence of vessel traffic on the operation of surface telescopic water intake / A. A. Lipin, N. Z. Rustamova // AzDDA “Elmi Əsərləri”, - Baku, -2020. No. 2 -s. 67-72.
10. Gasanov, S.T., Device for water intake, İxtira a2020 0073, Patent of the Republic of Azerbaijan / Gasanov S.T., Lipin A.A.
11. Lipin, A.A. Telescopic water intake with a water well// “AzHvəM” EİB-nin “Elmi Əsərlər Toplusu”, - Baku, volume XLI, -2021. -With. 223-231.

12. Gasanov, S.T. Improving the design and increasing the stability of a telescopic water intake / S.T.Gasanov, A.A.Lipin // Hydraulic engineering. -2021. No. 4, -p. 58-63.
13. Lipin, A.A., Economic efficiency of telescopic water intake // XXXV International Scientific and Practical Conference "Russian Science in the Modern World". -Moscow -2021. -With. 32-35.
14. Lipin, A.A., Ensuring the stability of a vertical telescopic water intake using constant tension anchors // AzMIU "İnşaat" fakultəsinin 100 illik yubileyinə həsr olunmuş konfransın -2021. - With. 106-110.
15. Lipin, A.A., Separation of oil using a telescopic water intake // III International Scientific Conference "Priority areas of innovative activity in industry" -2021. -With. 75-78.
16. Lipin, A.A. Telescopic water intake with stilling well // Magazine of Civil Engineering. -2022. Article No 11209, -p. 1-8.
17. Lipin, A.A. Regulation of telescopic water intake operations // Slovak Journal of Civil Engineering. -2022. № 3 Volume 30, -p. 27-32.
18. Lipin A.A. Hydraulic calculations of telescopic water intake / A.A.Lipin, A.Sepahvand, N.Z.Rustamova // Slovak Journal of Civil Engineering. -2023. № 2 Volume 31, -p. 61-69.

Lipin Andrey Alexandrovich

Water intake operating at a constant flow rate with variable head in a reservoir

Annotation

An analysis of the designs of existing water intake structures showed that they have certain disadvantages that make it difficult for their construction and operation. At the same time, the improved design of the vertical telescopic water intake avoids these problems.

Based on the analysis of the design of the telescopic water intake, its insufficient stability was revealed when resisting external influences. According to the results of analytical studies and computer modeling of the impact of wind, snow, ice loads, loads caused by the current, etc. structural solutions were proposed to increase the stability of the telescopic water intake from external influences. A study of the existing structures of the telescopic water intake revealed the absence of a constructive solution for regulating and stopping water intake, as well as a design for protection against the ingress of floating objects and debris. As a result of analytical studies and computer modeling, a design solution was proposed to stop water intake with the help of an additional ballast pontoon and a method for its calculation was proposed. A design solution was proposed to protect the telescopic water intake from the ingress of floating objects and debris into it.

On the basis of analytical calculations and experiments on computer models, a method for hydraulic calculation of the design of a telescopic water intake was developed. It has been established that high flow rates in the outlet tract of a telescopic water intake lead to the destruction of the bottom and slopes of the channel during open transportation. To solve this problem, the design of the downstream waterworks was developed. On the basis of analytical studies and computer modeling, a method for hydraulic calculation of the design of a water well has been developed.

Based on study of the design of telescopic water intake, the scope of its application and purpose were established.

The substantiation of the economic efficiency of the improved design of the vertical telescopic water intake is given. It is established that the expected economic benefit per unit over a period of 10 years will be 57%.

Claimant's personal contribution in manuscripts:

(1, 2, 3, 4, 5, 6, 7, 8, 11, 13, 14, 15, 16, 17) the author performed alone. In the scientific works (9, 10, 12, 18), the author took part in formulating the problem, performing experimental research and analyzing the obtained results.

The dissertation defense will be held on 29 September, 2025 at 14⁰⁰ at the meeting of the BFD 2.37 One-Time Dissertation Council, established on the basis of the FD 2.37 Dissertation Council operating under the Azerbaijan University of Architecture and Construction.

Address: AZ1073, Baku city, A.Sultanova street. 11. AzMIU, II building, III floor conference hall

The dissertation work can be viewed in the library of the Azerbaijan University of Architecture and Construction.

Electronic versions of the dissertation and abstract are posted on the official website of the Azerbaijan University of Architecture and Construction.

The abstract was sent to the necessary addresses on 25 June 2025.



Signed for print: 18.06.2025

Paper format: 60x84^{1/16}

Volume: 39627

Number of hard copies: 20