

REPUBLIC OF AZERBAIJAN

Under Manuscript Rights

**IMPROVING THE QUALITY INDICATORS OF HARD-
TO-MACHINE PARTS USING THE HYDROABRASIVE
PROCESSING METHOD**

Specialization: 3313.01 - “Mechanical Engineering Technology”

Field of Science: Technical Sciences

Applicant: **Samir Fariz oglu Amirli**

Abstract of the Dissertation

Submitted for the Degree of Doctor of Philosophy

Baku - 2025

The dissertation work was carried out at the "Mechanical Engineering Technology" department of Azerbaijan Technical University and the "Metal Cutting Machines" department of Brandenburg Technical University Cottbus-Senftenberg in Germany.

Scientific Supervisors: 1. **Nizami Damir oğlu Yusubov** – Honored Engineer, Doctor of Technical Sciences, Professor

2. **Sylvio Simon** – Honorary Doctor of AzTU, Doctor of Technical Sciences (Dr.-Ing.habil.), Professor

Official Opponents: Doctor of Technical Sciences, Professor **Vaqif Abbas oğlu Abbasov**

Doctor of Technical Sciences, Professor **Yusif Nadir oğlu Hasanov**

Candidate of Technical Sciences, Associate Professor **Madar Arif oğlu Guliyev**

BFD 2.09/2 Dissertation Council under the Higher Attestation Commission of the Republic of Azerbaijan, operating under Azerbaijan Technical University

Chairman of the Dissertation Council:



Doctor of Technical Sciences, Professor **Akbar Gulahmad oglu Huseynov**

Scientific Secretary of the Dissertation Council:

A handwritten signature in black ink, appearing to read 'F. Rasulov', is written over a horizontal line.

Doctor of Philosophy in Technical Sciences, Associate Professor **Fuzuli Rasul oglu Rasulov**

Chairman of the Scientific Seminar:

A handwritten signature in black ink, appearing to read 'V. Movlazada', is written over a horizontal line.

Doctor of Technical Sciences, Professor **Vaqif Zahid oglu Movlazada**

GENERAL CHARACTERISTICS OF THE STUDY

Relevance of the topic and degree of development: Waterjet cutting is classified within the group of cutting processes with geometrically undefined cutting edges according to the German Institute for Standardization (DIN 8580).

In modern mechanical engineering, the production of various equipment components increasingly relies on wear-resistant materials. Among these materials, new-generation steels alloyed with chromium and nickel stand out. One such steel is HARDOX-500, a high-strength wear-resistant material. HARDOX-500 steel plates are produced in thicknesses ranging from 4,0 mm to 103 mm, with widths of up to 3350 mm and lengths reaching 14630 mm. HARDOX-500 steel is widely used in the manufacturing of load-bearing vehicle body parts, cutting teeth of excavation machinery buckets, ship hulls, and other wear-resistant components within the mechanical engineering industry. Although HARDOX-500 steel exhibits high efficiency in terms of bending and welding and demonstrates excellent wear resistance, its mechanical processing through traditional methods such as milling, turning, drilling, cutting, and grinding presents significant challenges. The machining of components made from HARDOX-500 using these conventional methods is complex and results in high-cost technological processes.

Considering these factors, the application of innovative technologies in the production of machine components from HARDOX-500 steel allows for enhanced machining quality, improved productivity, and increased economic efficiency.

One of the modern mechanical machining methods used in the production of machine components is hydroabrasive cutting of workpieces. In contemporary mechanical engineering enterprises, hydroabrasive cutting of metals, segmentation of workpieces, and the production of contour surfaces of parts with high precision and accuracy are carried out using numerically controlled (NC) machines with advanced structural designs. The hydroabrasive cutting process is performed at pressures of 2000–3500 bar, depending on the

thickness of the workpiece, by adding abrasive particles of various concentrations into the waterjet.

A distinguishing feature of the hydroabrasive cutting method, compared to other mechanical and thermophysical machining processes, is that the cutting operation is carried out using a high-speed, high-pressure waterjet mixed with abrasive particles of various grain sizes. In the machining of chromium-nickel alloyed steels, traditional turning, milling, drilling, and other technological methods generate high temperatures, causing significant heating and rapid wear of cutting tools. Since hydroabrasive machining is performed using an abrasive mixture introduced into a high-pressure waterjet, no significant structural transformations occur on the cut surface. Many researchers, including M.A. Tamarkin, E.A. Kosenko, A.V. Sarazov, A.A. Barzov, A.L. Galinovsky, Y.K. Yaglitsky, T.V. Ereshenko, N.A. Mikhailova, M. Kaufeld, F. Pude, M. Linde, and others, have conducted experimental and theoretical studies on the technological input and output parameters of the hydroabrasive metal cutting process. These scientific works are dedicated to the improvement of hydroabrasive machining and the enhancement of cutting efficiency.

Research has shown that although hydroabrasive machining of workpieces, including chromium-nickel alloyed steels, is an advanced technological process, it also has several drawbacks. For instance, in hydroabrasive cutting of steel workpieces, depending on their thickness, ensuring the geometric profile of the cut surface and the perpendicularity of the cut face relative to the reference surface is a complex technological issue. Additionally, the uneven distribution of surface roughness along the contact area during abrasive waterjet cutting, changes in hardness on the machined surface, and similar issues lead to various negative consequences.

Studies have shown that in the hydroabrasive cutting process of HARDOX-500 chromium-nickel alloyed steels, the investigation of factors such as geometric form errors of the machined surface, roughness and waviness tendencies, hardness variations of the material during the technological operation, and other parameters depending on the cutting regime, as well as the scheme of waterjet delivery to the abrasive contact zone, has not been extensively explored. The development of a mathematical model for optimal

technological regimes in the hydroabrasive cutting process of HARDOX-500 steel, along with the determination of empirical coefficients in the variation of relevant technological parameters, has not been sufficiently addressed. The study of the interaction between feed rate, the flow velocity of the abrasive with the waterjet, the concentration and granularity of abrasive particles, and the physical-mechanical properties of the machined material in the hydroabrasive cutting of HARDOX-500 chromium-nickel alloyed steels represents both a pressing issue in mechanical engineering and the subject of this dissertation.

Research object and subject: The research focuses on the hydroabrasive machining process of complex-profile parts made from HARDOX-500 chromium-nickel alloyed steel. It involves the investigation of the regularities in the variation of surface geometric form and deviations, roughness, waviness, and hardness during the cutting of HARDOX-500 steel workpieces of different thicknesses, as well as the development of a new abrasive waterjet cutting technology.

Aim and objectives of the research: The aim of the dissertation is to theoretically and experimentally investigate the changes in the physical-mechanical properties, roughness, waviness, hardness, and geometric dimensions of the surface formed during the hydroabrasive cutting of parts made from HARDOX-500 chromium-nickel alloyed steel.

The solution to the identified problems requires the study of the following issues:

1. Theoretical investigation of the characteristics of chip formation during the hydroabrasive cutting of chromium-nickel steels.
2. Investigation of the dependency of the average and maximum surface roughness values on the technological regime parameters during the production of parts from HARDOX-500 steel.
3. Study of the dependence of the mechanism of waviness formation on technological factors during the hydroabrasive cutting of chromium-nickel steels.
4. Theoretical and experimental analysis of the mechanism of changes in surface hardness as a function of technological parameters in the hydroabrasive cutting of HARDOX-500 steel.

5. Improvement (optimization) of the technological regime parameters and cutting scheme for the production of parts from HARDOX-500 steel using hydroabrasive machining.

Research methods: The research is based on the production of parts from HARDOX-500 chromium-nickel alloyed steel using hydroabrasive machining, carried out on a FLOW-GUT model machine equipped with digital software (at the Laboratory of the Metal Cutting Machines Department, Brandenburg Technical University, Germany).

The studies were conducted based on the principles of machining technology, the theory of free hydroabrasive cutting of metals, the application of hydrodynamic laws, mathematical statistics, and the theory of relativity, as well as the fundamentals of friction and wear processes occurring during abrasive waterjet cutting.

The experimental data processing results were evaluated using the Student's t-test, Fisher's criterion, and Cochran's criterion, employing mathematical statistics methods.

The processing of experimental results was carried out with the help of the M-EXEL-2016 software and using the multifactorial planning method for the research.

Key Propositions Defended:

1. The theoretical issues of chip formation in the hydroabrasive cutting of HARDOX-500 chromium-nickel alloyed steel, depending on the cutting scheme.

2. The fundamentals of roughness and waviness formation in the hydroabrasive cutting of HARDOX-500 steel workpieces, based on the physical-mechanical properties of the material, and dependent on the thickness of the workpiece.

3. The mathematical regularity of the change in the physical-mechanical properties (hardness) of the surface in the hydroabrasive cutting of HARDOX-500 chromium-nickel alloyed steel, depending on the technological regime parameters.

4. Development of a new hydroabrasive cutting scheme to improve the geometric accuracy of the cut surface.

5. A new technological cutting process derived from the formation of the contact surface in hydroabrasive cutting.

The scientific novelty of the research is as follows:

1. A mathematical equation has been developed for the sum of the inertia forces created by abrasives in cutting, depending on the scheme of delivering the water-abrasive mixture to the processing surface in hydroabrasive material cutting.

2. Empirical equations for cutting forces (P_z , P_y , P_x) in free abrasive cutting, depending on the regime parameters, as well as the physical-mechanical properties of the abrasives and the processed material, have been found. Based on these properties, the characteristics of the chip formation process have been studied.

3. The regularity of the distribution of roughness and machining accuracy on the cut surface of the workpiece during the cutting of HARDOX-500 steel has been determined, depending on the cutting regimes.

4. The mechanism of changes in the hardness of the material on the processed surface during the hydroabrasive cutting of the workpiece from HARDOX-500 steel has been identified. It has been found that the process increases hardness by 10-15%, which improves the wear resistance of the component surface.

5. The inclination angle of the cut surface, depending on the thickness of the workpiece during hydroabrasive cutting, has been determined. That is, the mechanism of the surface's inclination relative to the base surface has been established.

6. A new technological cutting scheme has been proposed for ensuring the perpendicularity of the cut surface relative to the base surface during hydroabrasive cutting of HARDOX-500 steel components. This scheme was tested at an industrial enterprise of the Republic of Azerbaijan and as a result, the accuracy of the cut surface relative to the positioning base surface increased.

7. Optimal parameters for the cutting regimes of HARDOX-500 steel, depending on the material's physical-mechanical properties, have been developed.

8. A new design of a ring regulating the pressure of the waterjet to prevent air loss has been developed and produced, and it has been applied in the new technological process on the FLOW-Gut RPI machine.

The theoretical and practical significance of the research: The theoretical significance of the completed dissertation work lies in the theoretical investigation of the chip formation problem in the hydroabrasive machining of complex profiled surfaces made of chromium-nickel steel, the mathematical models of roughness, waviness, hardness, and geometric dimensional errors of the cut surface, as well as the development of new hydroabrasive cutting technology schemes and regimes.

The mathematical algorithms of the dependencies of the formation of roughness, waviness, and hardness, depending on the thickness of the workpiece in the hydroabrasive cutting of HARDOX-500 chromium-nickel steel, have been developed.

New hydroabrasive machining technology schemes and theories have been developed to improve the geometric dimensional accuracy of the cut.

The limits of the variation of technological regimes ensuring the quality parameters of the machined surface in the cutting of HARDOX-500 steel have been determined.

The results obtained in the dissertation were tested at a production facility in our Republic and a conditional economic benefit of 40,000 AZN was achieved.

Publication, approval, and application of the work: The main findings of the dissertation have been discussed at national and international conferences, symposiums, and seminars:

1. II International Scientific-Practical Conference on “Mechanical Engineering and Energy: New Concepts and Technologies”, December 4-5, 2023, Baku, Azerbaijan Technical University (AzTU).

2. VI International Scientific-Practical Conference on “Energy and Resource-Saving Technologies: Experience and Prospects”, April 18, 2024, Kyzylorda: Korkyt Ata State University.

3. “International Symposium on Unmanned Systems: Artificial Intelligence, Design, and Efficiency” (ISUDEF'24), May 22-24, 2024, National Aviation Academy, Baku.

4. XIII All-Russian Scientific-Practical Conference on Professional Communication in the Scientific Environment – A Factor Ensuring Research Quality, April 16, 2024, Almetyevsk, Kazan National Research Technical University, Almetyevsk Branch, A.N. Tupolev - KAI.

5. IX National Scientific-Technical Conference on “Advanced Technologies and Innovations”, May 1-2, 2024, Baku, AzTU.

6. XII International Scientific-Practical Conference on “Modern Problems of Machine Theory”, May 31, 2024, St. Petersburg.

7. VI International Congress on Science and Engineering of the Turkic World. December 19-21, 2024, Baku, AzTU.

8. VI International Conference on Emerging Trends in Information Technology, Robotics, Design, Engineering, and Applied Sciences (ETITR-AUG-2024), August 26-27, 2024, Amsterdam, Netherlands.

9. II International Scientific-Technical Conference on “Infocommunication Systems and Artificial Intelligence Technologies”, December 4-5, 2024, Baku, AzTU.

The materials presented in the dissertation, including the regime parameters and new technological methods determined through theoretical and practical research in hydroabrasive cutting, are applied in the production of variously configured parts.

A total of 15 scientific works have been published based on the dissertation, including 9 articles and 6 conference abstracts and proceedings. Seven articles have been published in peer-reviewed scientific journals included in international indexing and abstracting databases recommended by the Higher Attestation Commission. Among the 6 works published based on the results of national and international scientific events, 3 were published abroad. In total, 6 works have been published within the country, while 9 have been published internationally.

The materials presented in the dissertation have been recommended for use in teaching at the Azerbaijan Technical University, specifically in the undergraduate program 050622 –

“Mechanical Engineering” for the course “Design of Technological Processes in Mechanical Engineering” and in the master's program 050622 – “Mechanical Engineering” for the course “Research Methods”.

Name of the institution where the dissertation was conducted. The dissertation research was carried out at the “Mechanical Engineering Technology” department of Azerbaijan Technical University and the “Metal Cutting Machines” department of Brandenburg Technical University Cottbus-Senftenberg, Germany.

Candidate's personal contribution to the research. In the dissertation, the candidate substantiated the relevance of the research, identified the necessary objectives to achieve the set goals, determined the sequence of research activities, and carried out their implementation. The candidate independently conducted computer modeling of the theoretically obtained models, planned the experiments using a multifactor matrix, systematized the results, analyzed the findings of the experimental studies, participated in discussions at scientific conferences, and independently prepared scientific articles.

The structure of the dissertation with the volume of each section specified in terms of character count. The dissertation consists of an introduction, four chapters, 172 pages of computer text, 51 figures, 20 graphs, 43 tables, a list of 145 references, appendices, and abbreviations. The structure of the dissertation includes the cover page and table of contents (5423 characters), introduction (13384 characters), Chapter I (54490 characters), Chapter II (27675 characters), Chapter III (29738 characters), Chapter IV (84932 characters), conclusion (6034 characters), references used (145), bibliography of the dissertation (24726 characters), and the list of appendices, abbreviations, and symbols (13369 characters). The total volume of the dissertation, excluding figures, tables, graphs, and the bibliography, is 259771 characters.

MAIN CONTENT OF THE WORK

In the **introduction of the dissertation**, the relevance of the topic is justified, the goals and objectives of the research are clearly expressed, the scientific novelty, practical significance, and the main theses presented for defense are provided.

The **first chapter** presents the literature review of scientific studies dedicated to the research of the hydroabrasive processing method. It has been emphasized that in various fields of the machine-building industry, including automobile, aircraft, shipbuilding, and other production processes, in addition to a number of mechanical processing methods, hydroabrasive machining technologies are also widely used during the technological processes of parts manufacturing. The physical essence of the hydroabrasive cutting process of materials and metals, although similar to other mechanical processing methods such as turning, grinding, milling, drilling, drawing, etc. (i.e., the removal of a metal layer from the workpiece surface for the production of the desired part follows the same principle), is noted to have principal technological differences.

The removal of material in hydroabrasive metal cutting and the formation of burrs is carried out through abrasive particles mixed with high-pressure water supplied to the cutting zone. Hydroabrasive processing is performed on special machines that differ in their kinematic and structural characteristics from other metal cutting machines.

The cutting of metals by hydroabrasive method is carried out based on the schematic given below (Figure 1)¹.

The analysis results indicate that during the hydroabrasive metal cutting process, abrasive particles mix with a high-pressure waterjet, creating an erosion effect on the processed surface, forming chips, and subsequently washing them away from the cutting zone.

¹ Nozirezoda, Sh.S. *Prospects for the Development of Hydroabrasive Processing // VIII International Scientific and Technical Conference of Young Scientists, Postgraduates, and Students "High Technologies in Modern Science and Technology"* – Tula, 2019. – pp. 339-341.

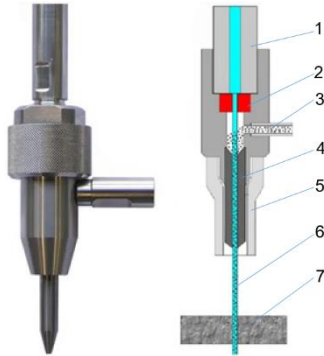

Figure 1. Hydroabrasive cutting diagram

1-water container (pressure up to 4000 bar); 2-nozzle; 3-abrasive grain delivery area; 4-water and abrasive mixing chamber; 5-mixing pipe; 6-hydroabrasive cutting jet, 7-material being cut

Research has shown that in modern times, hydroabrasive cutting machines are successfully used in various sectors of the mechanical engineering industry for manufacturing machine parts from sheet steel materials with a thickness of up to 300 mm.

The application of hydroabrasive cutting machines for manufacturing parts from chromium-nickel steel blanks requires the investigation of surface roughness, dimensional accuracy, hardness variations on the cut surface, and other related factors. These aspects represent pressing challenges in the field of mechanical engineering. Since the technological regimes for processing machine parts made from HARDOX-500 chromium-nickel steel using hydroabrasive cutting machines have not been extensively studied, further research in this area is necessary to support the broader adoption of hydroabrasive cutting methods for producing such components.

The theoretical and practical results of the conducted studies indicate that a generalized approach to the mathematical modeling of technological regime parameters for hydroabrasive machining in machine part production has not yet been established.

Based on the research findings, the first chapter substantiates the relevance of the dissertation topic and defines the objectives and tasks of the study.

The **second chapter** discusses the theoretical investigation of the chip formation process during the hydroabrasive machining of chromium-nickel-based HARDOX-500 steel. This analysis is crucial for selecting the optimal regime parameters. It is highlighted that chip formation and separation in the contact zone during hydroabrasive cutting depend on multiple factors, including the physical and mechanical properties of the workpiece and abrasive grains, the velocity of the waterjet mixed with abrasive grains, the feed rate, and the angle at which the waterjet impacts the machined surface. It is noted that to study the mechanism of chip formation in hydroabrasive machining and its dependence on technological parameters, it is necessary to develop theoretical calculations of the process's dynamic indicators. Based on this, the waterjet pressure should be determined, along with the inertial pressure exerted by the abrasive grains on the contact surface and the dependence of the cutting force exerted by each abrasive grain on the chip formation process.

In the hydroabrasive cutting of materials, including steels, the separation and transportation of chips from the workpiece surface are carried out using a high-pressure and high-velocity waterjet mixed with abrasive grains directed into the contact zone.

Depending on the scheme of supplying the water-abrasive mixture to the workpiece surface, the pressure forces generated in the contact zone vary. This leads to different physical processes occurring during the technological production of machine components.

Next, the schemes for supplying the water-abrasive mixture to the workpiece surface and the calculations of the total and inertial (momentum) pressure forces of the waterjet depending on these schemes are presented. Figure 2 illustrates two methods of delivering the water-abrasive jet to the machining surface in hydroabrasive processing.

The investigation of the hydroabrasive machining process shows that in this method, the waterjet mixed with abrasives, which acts as the cutting tool, is supplied to the cutting zone through a centrally directed free feed.

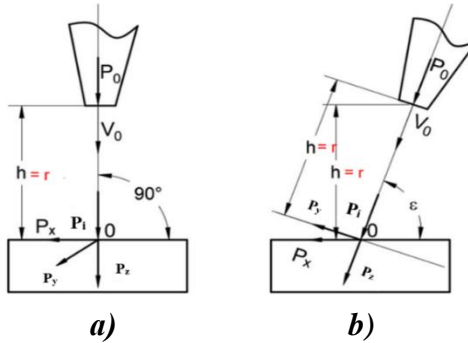

Figure 2. Schemes for calculating the pressure force in different cutting schemes

a)- scheme of the waterjet being supplied perpendicularly to the surface;

b)- scheme of the waterjet being supplied at an angle (inclined) to the surface

Initially, the turbulent fluid is guided from the nozzle in a linear flow towards the machined surface. The high-pressure waterjet with abrasives strikes the machined surface at point “O”. In this case, the pressure created at point “O” due to the impacts of the waterjet mixed with abrasives can be expressed as follows:

$$P = P_o + P_i \text{ (IIa)}, \quad (1)$$

here

P - total pressure of the waterjet at point “O”;

P_o - pressure of the waterjet at the nozzle exit;

P_i - inertial force generated by the impact on the cutting surface at point “O”.

Based on the theory of changing the trajectory of the waterjet delivery to the cutting zone, the force generated in the inertial pressure P_i as a function of time (dt) can be expressed as follows:

$$P_i dt = m Q dt \cdot v_o, \quad (2)$$

here

m - weight of the abrasive particles transported by the water jet, g/s ;

Q - water consumption, l/s ;

v_o - flow velocity of the waterjet with abrasive, m/s .

In equation (2), $mQdt \cdot v_o$ – represents the total change in the movement of the waterjet.

By solving the total motion equation of the waterjet, the inertial force can be expressed as follows:

$$P_i = mQ \cdot \vartheta_o = \frac{Z \cdot m_z \cdot \vartheta_o^2}{r}, \quad (3)$$

here

Z - number of abrasive particles impacting the machined surface per second;

m_z - average weight of abrasive particles with water, kg;

ϑ_o - average impact velocity of abrasive particles on the machined surface, m/s ;

r - impact radius of abrasive particles, i.e., the distance from the nozzle exit to the machined surface, m.

The hydrodynamic analysis of the mixture of the waterjet and abrasive particles shows that the pressure force generated on the machined surface is greater than P_o by $Z \cdot m_z \cdot \vartheta_o^2/r$, i.e.,

$$P = P_o + P_i = P_o + \frac{Z \cdot m_z \cdot \vartheta_o^2}{r}, \left(\frac{kg \cdot m^2}{m \cdot s^2} \right) (\text{Па}) \quad (4)$$

Equation (4) represents the scheme of the hydroabrasive cutting method shown in Figure 2a. That is, it corresponds to the scheme where the waterjet impacts the machined surface perpendicularly. If the waterjet is applied to the machined surface at an angle “ ε ”, then the resulting inertia force can be expressed as follows:

$$P_i = mQ\vartheta_o \cdot tg\varepsilon$$

or

$$P_i = \frac{Z \cdot m_z \cdot \vartheta_o^2}{r} \cdot tg\varepsilon. \quad (5)$$

Thus, in the scheme shown in Figure 2b, the total pressure generated at point “O” on the surface of the workpiece will be expressed as follows:

$$P = P_0 + \frac{Z \cdot m_z \cdot \vartheta_0^2}{r} \operatorname{tg} \varepsilon. \quad (6)$$

The investigation of the hydro-abrasive machining process shows that due to the different total pressures generated in various cutting schemes, changes occur in the direction of chip removal by the waterjet from the contact zone. Theoretical studies have revealed that the penetration of abrasive particles into the metal depends on the shape and size of their sharp edges, leading to different chip formation patterns influenced by the pressures P_0 and P_i .

Theoretical and practical research indicates that the penetration angles of cutting particles into the metal vary depending on the shape of the abrasive particles' edges and the sharpness angle of each edge. It has been determined that when an abrasive particle strikes the metal, its central axis rotates at an angle ε_1 at the contact point. The value of this rotation angle is highly dependent on the shape of the abrasive particle.

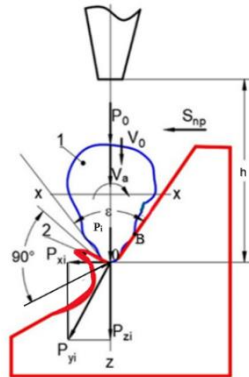

Figure 3. Scheme of abrasive particle penetration into metal.

1 — abrasive particle; 2 — chip

Figure 3 illustrates the penetration scheme of an abrasive particle into the metal in the contact zone.

In the experiments, granite sand was used as the abrasive material. Granite sand is natural, possesses high hardness, and has a lower production cost compared to synthetic abrasives. The hardness of granite sand particles ranges from 7,5 to 8,0 on the Mohs scale, and they have sharp-edged, precise shapes. The geometric form and dimensions of the abrasive particles used in the experiments were thoroughly studied using a Nikon SMZ-10A microscope.

As seen in Figure 3, during hydro-abrasive cutting of materials, the total pressure and inertia (momentum) forces are divided into their components, generating the cutting force components P_{zi} , P_{yi} and P_{xi}

Here, P_{zi} is the tangential cutting force, P_{yi} is the normal cutting force, P_{xi} is the axial cutting force, each representing the forces generated by individual abrasive particles in the XYZ coordinate system. If we consider that, under the influence of the applied pressure P_o , the abrasive particles mix with water and are delivered to the cutting zone at a velocity of v_o , then the number of particles striking the machining surface and participating in chip formation depends on the concentration of the abrasive material in the water mixture. Taking this into account, the components of the cutting forces P_z , P_y and P_x can be determined from the following relationship:

$$\begin{aligned} P_z &= \sum P_{zi} = Z \cdot P_{zi} ; \\ P_y &= \sum P_{yi} = Z \cdot P_{yi} ; \\ P_x &= \sum P_{xi} = Z \cdot P_{xi} , \end{aligned} \quad (7)$$

here

Z - the number of abrasive particles generating chips during the cutting process;

P_{zi} , P_{yi} , P_{xi} - the respective tangential, normal, and axial cutting forces generated by the abrasive particles during cutting.

The equation for the cutting forces generated by an abrasive particle can be written as follows.

$$P_{zi,yi,xi} = (P_0 + \frac{Z \cdot m_z \cdot \vartheta_0^2}{r}) \cdot S ; \quad (8)$$

here

S - the area of the cut layer in m^2 .

Considering the regime parameters in hydroabrasive cutting, the components of the cutting forces created by an abrasive particle can be written as follows.

$$\begin{aligned} P_{zi} &= C_{pz} \cdot Q_{pz}^{xz} S_{np}^{yz} t^{zz} ; \\ P_{yi} &= C_{py} \cdot Q_{py}^{xy} S_{np}^{yy} \cdot t^{zy} ; \\ P_{xi} &= C_{px} Q_{px}^{xx} \cdot S_{np}^{yx} \cdot t^{zx} . \end{aligned} \quad (9)$$

here

C_{pz} , C_{py} and C_{px} - coefficients that take into account the cutting conditions and the physical-mechanical properties of the processed material;

Q_p – the consumption of the water jet with abrasive particles per minute;

S_{np} - the longitudinal feed rate of the nozzle (or workpiece) in m/min ;

T - cutting depth (the width of the cut created during the process;

x, y, z - the force values for the respective directions.

This chapter addresses the optimization of regime parameters for the hard-to-process HARDOX-500 material, and systematic approaches to optimization algorithms for hydroabrasive processing have been developed and investigated.

In the **third chapter**, the methodology for researching the hydroabrasive processing of HARDOX-500 steel has been developed.

Experimental studies were conducted at the “Mechanical Engineering Technology” department of the Azerbaijan Technical

University and in the laboratory of the “Metal-Cutting Machines” department at the Brandenburg Technical University Cottbus-Senftenberg in the Federal Republic of Germany. The experiments were performed on a CNC-controlled FLOW-Gut model hydroabrasive cutting machine.

This chapter places significant emphasis on the planning of experiments to study the impact of input parameters on the resulting surface roughness, shape deviations, hardness, and other output parameters in hydroabrasive cutting. In experiment planning, requirements for input parameters and their influence on the multifactorial solution of the study were examined.

In hydroabrasive cutting, the input parameters considered include water jet pressure (P , MPa), abrasive particle hardness (T), water jet consumption (Q , g/s), feed rate (S_{long}), and the thickness of the processed workpiece (b , mm), the investigated output parameters include surface roughness (R_a , R_z , μm), dimensional deviations (Δ , μm), hardness (H_μ MPa) and other related factors. The planning of experiments was carried out using a full-factorial 2^3 matrix design. After conducting the experiments, statistical analysis of the results was performed. The dispersion of the mean quadratic deviations of the factors was verified using the Cochran criterion to check the homogeneity of variance. Based on the corresponding tables, the obtained results were found to be adequate.

Regression coefficients were calculated based on the natural and dimensionless values of the factors. As a result, using a three-factor experiment, the following mathematical relationship for the surface roughness R_a was determined.

$$R_a = -0,01 + 0,016P + 0,017Q + 0,102S_{\text{long}} - 0,000038PQ - 0,00042PS_{\text{long}} - 0,000339QS_{\text{long}} + 0,000001PQS_{\text{long}} \quad (10)$$

As seen from equation (10), the longitudinal feed rate has the most significant effect on surface roughness, as its coefficient is 0,102, which is higher than the coefficients of other factors. The impact of other factors can also be observed accordingly from equation (10). For example, the waterjet flow rate (Q , g/s) is the second most influential factor on roughness after the longitudinal feed rate. On the other hand,

the water jet pressure (P , MPa) and the product of $PQ S_{long}$ positively affect surface roughness, meaning that an increase in these factors leads to increased roughness. Conversely, the interaction terms PQ , PS_{long} , and QS_{long} negatively impact roughness, meaning that an increase in these factors reduces surface roughness.

Graph 1 presents the variation of R_a based on the feed rate, obtained using Microsoft Excel.

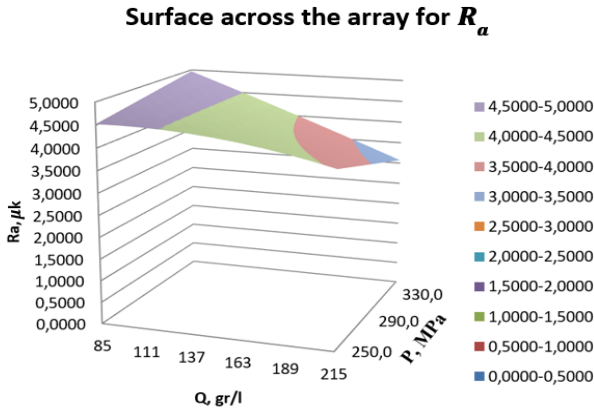

Graph 1. Variation of R_a based on feed rate across the workpiece

Additionally, the dependency of the hardness of HARDOX-500 steel on the selected factors during hydroabrasive cutting is expressed by the following regression equation:

$$H\mu = 495,9440266 - 0,169021328 * P - 0,177969924 * Q + 1,430359217 * S + 0,001356 * P * Q + 0,003406 * P * S + 0,0022 * Q * S - 0,000008 * P * Q * S. \quad (11)$$

This chapter also presents the research methods and instruments used to study surface roughness, form errors, and hardness in hydroabrasive cutting.

According to the research methodology, roughness values obtained at three different surface heights of the workpiece under

varying cutting conditions were examined.

The hardness measurements were conducted using a HECKERT model hardness tester. The device measures hardness based on its software system and automatically compiles the results into tables and graphs.

The theoretical calculations of the mathematical dependence of $H\mu$ on the influencing factors were performed using Microsoft Excel. The values obtained from changes in the feed rate are illustrated in Graph 2.

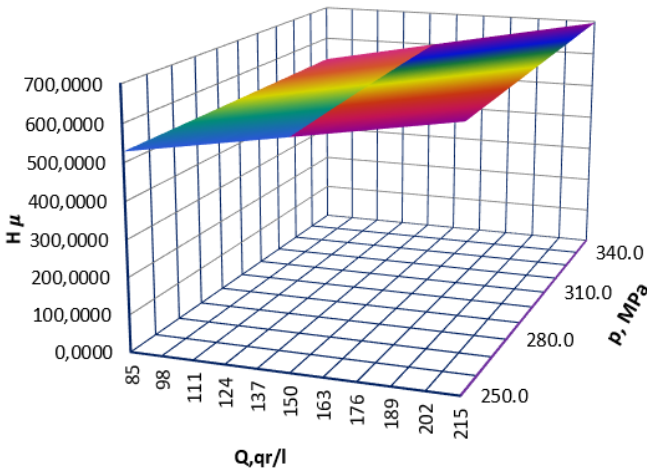

Graph 2. Surface view of hardness across the array

By cutting the workpiece under different hydroabrasive cutting conditions, the variation limits of hardness were analyzed, and the results were presented in the relevant sections as tables and graphs.

Based on the developed program, a methodology for studying the shape and size of abrasive grains used in hydroabrasive machining was developed, and measurements were conducted using a "Nikon SMZ-10" model microscope.

In the **fourth chapter**, the cutting method and scheme, as well as the influence of processing parameters on surface roughness, dimensional accuracy, hardness, and other factors during the

hydroabrasive machining of HARDOX-500 chromium-nickel steel, were investigated through experimental studies and analyzed.

As the thickness of the workpiece changes during the hydroabrasive machining of the selected material, the shape and dimensions of the cut vary significantly. This makes the study of the resulting roughness crucial for assessing the technological capabilities of this process.

The measurement coordinates of the roughness formed during hydroabrasive cutting are provided below in Figure 4.

At this stage, the distribution of roughness and waviness on the cut surface of the workpiece was studied at 3 mm from the top (left side), 3 mm from the bottom (right side), and along the central line. The geometric parameters of roughness and waviness were measured using the “JENOPTIK” device, starting from points 1, 2, and 3 indicated in Figure 4 (with point 0 as the reference), at distances of 4,20 mm; 8,40 mm; 12,60 mm and 16,80 mm.

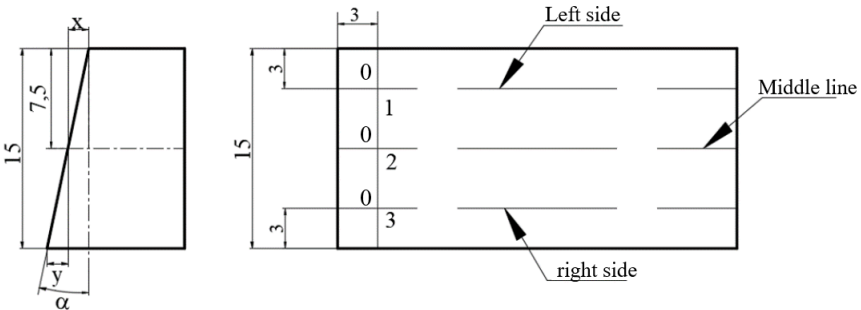

Figure 4. Measurement coordinates of the surface roughness and waviness of the cut workpiece at different longitudinal feed rates

The experimental measurements of each experiment are presented in this chapter as automatic calculations and computer graphics. For example, in Figure 5, the surface roughness measurements of a 15 mm thick steel workpiece cut by hydroabrasive machining, based on the scheme shown in Figure 4, are given. The roughness measurements taken 3 mm below the machining surface on the left cut show: the average roughness height R_a (Figure 5a), the

maximum roughness height R_z (Figure 5b), and the waviness S_m (Figure 5c) distribution on the same surface.

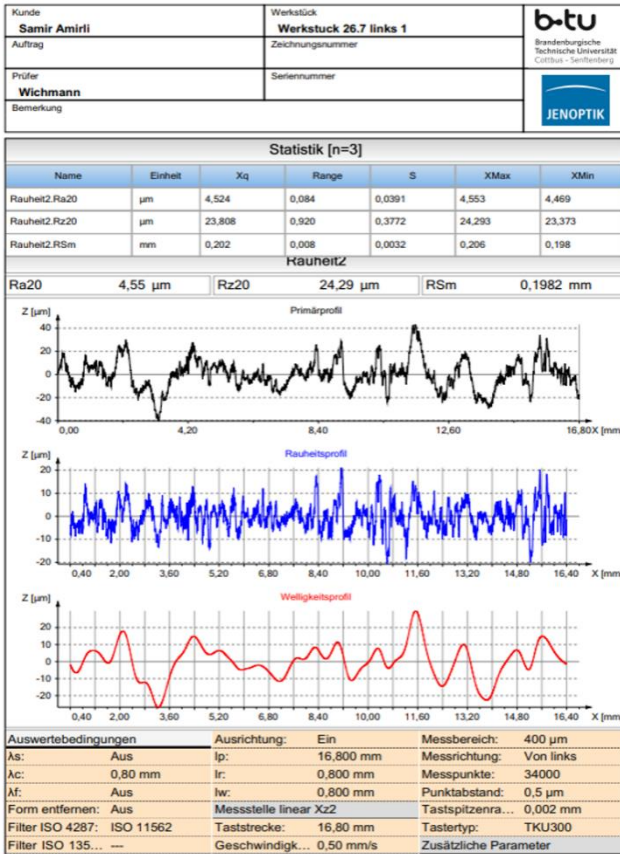
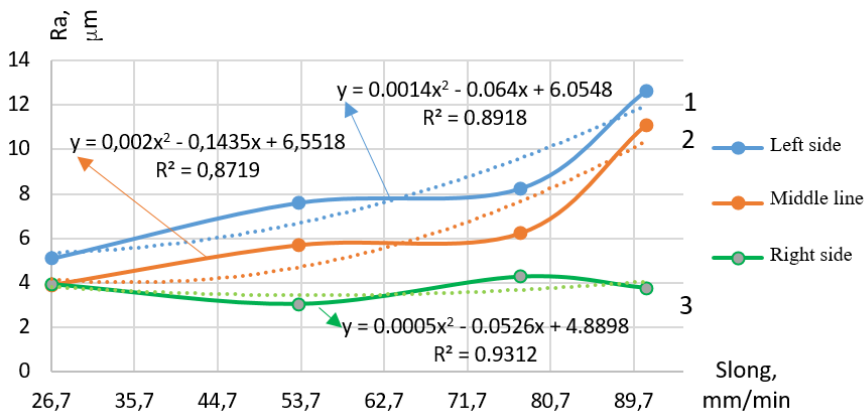

Figure 5. Results of measuring the surface roughness and waviness on the left side of the hydroabrasively cut workpiece using the JENOPTIK device

As a result of the conducted research, the experimental results of the dependence of the average roughness height R_a of the surface roughness formed during hydroabrasive cutting on the longitudinal feed are presented in Graph 3.



Graph 3. Experimental curves of the average roughness height (R_a) of surface roughness depending on the longitudinal feed movement for different width cuts

The mathematical expressions for the effect of S_{long} on R_a were calculated (Graph 2), and regression coefficients were determined based on the identified equations. Theoretical calculations revealed that the mathematical expressions of the curves obtained for the left, middle, and right width cuts of the workpiece differ depending on the characteristics of the graphs and are represented by different equations. The equations obtained from the mathematical calculations are given below.

$$\begin{aligned}
 R_{a1} &= 6,0716 - 0,0649S_{long} + 0,0014S_{long}^2 ; \\
 R_{a2} &= 6,5518 + 0,1435S_{long} - 0,002S_{long}^2 ; \\
 R_{a3} &= 4,8898 - 0,0526S_{long} + 0,0005S_{long}^2 .
 \end{aligned} \tag{12}$$

The regression coefficient R^2 for these curves ranges between 0,8719 and 0,9312, which confirms the accuracy of the R_a values obtained from the experiments.

Additionally, the maximum height of the roughness was studied under the same regimes, and the change in R_z based on the obtained values is presented in Graph 4.

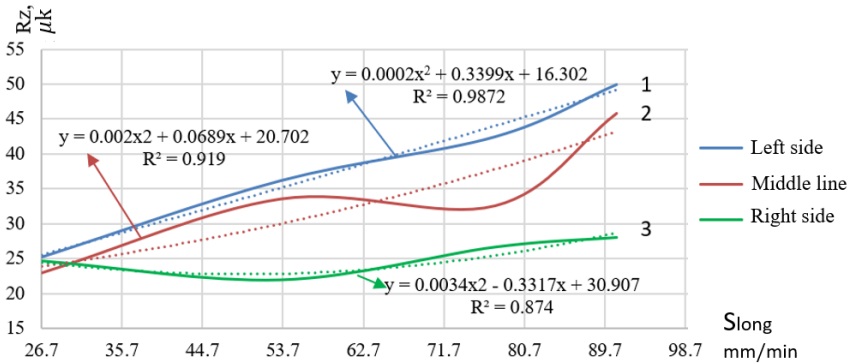

Graph 4. Dependency curves of the maximum roughness height (R_z) on the longitudinal feed (S_{long})

The mathematical solution of the dependency graphs of the maximum roughness height on the longitudinal feed obtained in Graph 4, as well as the calculation of the regression coefficient, have determined the dependencies given in equation (13).

$$\begin{aligned}
 R_{z1} &= 16,302 + 0,3399S_{long} + 0,0002S_{long}^2 \\
 R_{z2} &= 20,702 + 0,0689S_{long} + 0,002S_{long}^2 \\
 R_{z3} &= 30,907 - 0,3317S_{long} + 0,0034S_{long}^2
 \end{aligned} \quad (13)$$

The variations in roughness according to the given regularities are primarily explained by the mechanism of abrasive particles penetrating the cutting zone, as well as the fact that the conditions for chip formation along the central line of the cut workpiece's contact zone are better compared to the left and right lines.

The experiments have shown that as the feed rate increases, the density of the distribution of the mean roughness step S_m decreases. Specifically, at a longitudinal feed rate of $S_{long} = 26,7 \text{ mm/min}$, the mean roughness step values are $S_m = 0,2518 \text{ mm}$ for the left line, $S_m = 0,1525 \text{ mm}$ for the middle line, and $S_m = 1,005 \text{ mm}$ for the right line. When the feed rate increases to $S_{long} = 53,4 \text{ mm/min}$, the corresponding values change to $S_{m,left} = 0,2878 \text{ mm}$, $S_{m,middle} = 0,2335 \text{ mm}$, and $S_{m,right} = 0,1137 \text{ mm}$. Furthermore, as

shown in Graph 5, the mean roughness step increases accordingly at feed rates of $S_{long}=77,4 \text{ mm/min}$ and $S_{long}=91 \text{ mm/min}$.

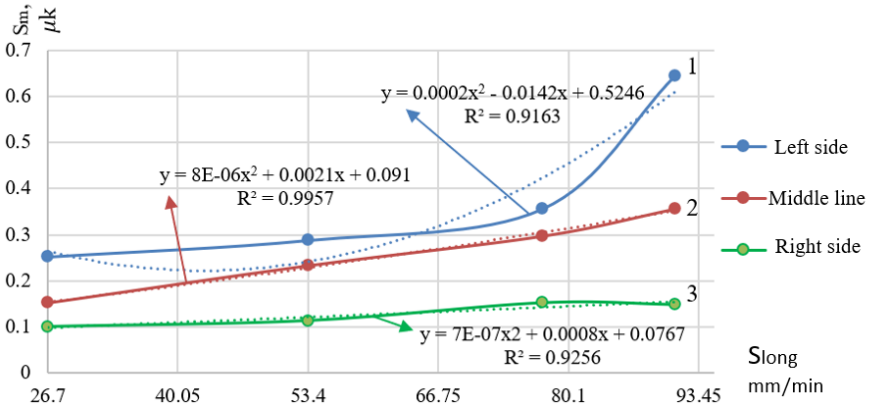

Graph 5. Variation curves of the mean roughness step depending on the longitudinal feed rate

The mathematical expressions of the graphs showing the dependence of the mean roughness step on the longitudinal feed rate are given in equation (14).

$$\begin{aligned}
 S_{m1} &= 0,5246 - 0,0142S_{long} + 0,0002S_{long}^2 ; \\
 S_{m2} &= 0,091 + 0,0021S_{long} - 0,000008S_{long}^2 ; \\
 S_{m3} &= 0,0767 + 0,0008S_{long} - 0,0000007S_{long}^2 .
 \end{aligned} \quad (14)$$

In addition, the threshold dimensions of roughness in the machining of workpieces with different thicknesses were experimentally determined, and the corresponding experimental and theoretical expressions were provided.

Furthermore, an experimental and theoretical study was conducted on the surface roughness formed during cutting, considering the grain size of the abrasive and the consumption of abrasive material. The obtained expressions for roughness, its mean step, and waviness during machining have been thoroughly addressed in the dissertation.

The dimensional accuracy of hydroabrasively cut workpieces was studied using two methods: analyzing deviations in linear dimensions and measuring with both a three-dimensional (3D) and two-dimensional (2D) system, utilizing a white light scanner. According to the research methodology, the machining accuracy in hydro-abrasive cutting was examined on a complex-profiled part with dimensions of 30×20×15 mm. For instance, the dimensional accuracy obtained in a workpiece cut under parameters of $S_{long}=77,4 \text{ mm/min}$ feed rate, 80 μm abrasive grain size, and 250 MPa water jet pressure is detailed in chapter four.

The surface hardness of HARDOX-500 chrome-nickel steel after hydroabrasive cutting was investigated based on different processing parameters and abrasive grain sizes. The results, including corresponding graphs and mathematical expressions, are presented in the dissertation. It was found that the surface hardness of HARDOX-500 steel increases by 10–18% after hydroabrasive cutting.

It has been found from the conducted research that the shape of the cut surface of hydroabrasively cut workpieces depends on the thickness of the workpiece and the variation in the feed rate, resulting in an inclined surface, i.e., an angle. Therefore, a new cutting scheme has been proposed to ensure the perpendicularity of the side surface of the cut in hydroabrasive machining. The essence of the new cutting scheme is that the workpiece is positioned at an angle depending on its thickness, and the machining process is carried out accordingly.

CONCLUSION

1. The mathematical equations for the inertial forces (P_i) generated by the abrasive particles and the cutting forces (P_z, P_y, P_x) involved in the chip formation during hydroabrasive cutting of HARDOX-500 steel have been determined, depending on the processing surface impact scheme of the water-abrasive jet and the regime parameters [5].

2. The mathematical equations for the inertia and cutting forces generated during the hydroabrasive cutting of chromium-nickel HARDOX-500 steel allow for the investigation of the physical nature of chip formation in this process and provide a basis for predicting ways to increase productivity [5].

3. The research results show that in the hydroabrasive cutting of HARDOX-500 steel workpieces, the formation of surface roughness (R_a, R_z) follows a complex pattern, with different values of roughness occurring at the initial, middle, and lower sections of the cut surface. The formation of roughness in this case depends not only on the hydroabrasive cutting scheme but also on the technological regimes of the process [1].

4. Depending on the thickness of the material being processed, rational values for the regime parameters of the technological process have been determined in order to improve the accuracy of the geometric dimensions obtained through hydroabrasive cutting, and corresponding recommendations have been developed [10].

5. Research has shown that during the hydroabrasive cutting of workpieces, the formation of surface roughness stabilizes across the entire surface area depending on the thickness of the material, and the average heights of R_a and R_z decrease [3].

6. In the hydroabrasive processing of HARDOX-500 grade steel, the influence of abrasive grain size and consumption on the formation of surface roughness and dimensional errors is highly significant. It is recommended that the optimal abrasive grain size be within the range of $80 \div 120 \mu\text{m}$, and their consumption in the water jet be $165 \div 215 \text{ g/l}$ [5].

7. In the cutting of steel using hydro-abrasive methods, the values of surface roughness and form errors on the workpiece surface

increase monotonically within the feed rate range of $26,7 \text{ mm/min}$ to 91 mm/min , with both R_a and R_z roughness parameters rising accordingly. Beyond the 91 mm/min threshold, roughness increases at a significantly higher intensity. Therefore, taking into account the surface roughness requirements of the processed part and the productivity of the process, it is recommended that the longitudinal feed rate be selected within the range of $26,7 - 91 \text{ mm/min}$ [4].

8. The impact of the waterjet pressure on the output parameters in hydroabrasive cutting is significant. Practical and theoretical experiments have shown that for cutting HARDOX-500 steel, the most optimal output parameter values (R_a, R_z, Δ, H_μ , etc.) are achieved when the water-abrasive jet pressure is within the range of $300 \div 350 \text{ MPa}$ [2], [3].

9. For hydro-abrasive cutting of circular surfaces with complex contours on cylindrical workpieces, setting the circular feed rate within the range of $75 \div 150 \text{ mm/min}$ ensures high precision, reducing dimensional errors ($\Delta = \pm 0,2 \div 0,5 \text{ mm}$). Under these cutting conditions, the surface waviness varies between $-0,06$ and $+0,07 \text{ mm}$ [1], [2].

10. One of the key quality parameters of machine parts is the hardness of the machined surface formed during processing. Research has shown that during hydroabrasive cutting of HARDOX-500 chrome-nickel steel, the surface hardness increases by $10 \div 15\%$, regardless of the cutting regime parameters. This increase is attributed to the plastic deformation caused by the high-impact collisions of abrasive particles with the machined surface during chip formation [11].

11. It has been determined that the increase in hardness of HARDOX-500 chrome-nickel steel cut by hydroabrasive machining enhances the wear resistance of the manufactured parts [8], [9].

12. Since ensuring the perpendicularity of the machined surface relative to its positioning base is one of the main technological requirements in cutting blanks, studies on hydroabrasive cutting of HARDOX-500 steel have shown that the contact surface formed during cutting becomes inclined relative to the base surface, depending on the process parameters. In this case, the deviation from perpendicularity of the cut surface to the base surface can be significantly large. Therefore, to ensure perpendicularity of the

surfaces, it is necessary to develop a new hydroabrasive cutting scheme [12].

13. Research has determined that the inclination of the cut surface relative to the positioning base surface increases depending on the thickness of the cut blanks and the feed rate. For example, when the thickness of the blank increases from 5 mm to 15 mm, the inclination angle (α) ranges from $1,78^\circ$ to $1,24^\circ$ at a feed rate of $S_{long} = 26,7 \text{ mm/min}$. Additionally, when the feed rate increases from $26,7 \text{ mm/min}$ to 91 mm/min (for a blank thickness of 15), the inclination angle increases from $1,78^\circ$ to $3,12^\circ$ [10].

14. In order to ensure the perpendicularity of the cut surface relative to the positioning base surface when cutting blanks of different thicknesses using the hydroabrasive method, the blank should be positioned at a required angle in the machine's working zone, based on its thickness or the feed rate. Specifically, the blank's base surface should be inclined at the required angle relative to the nozzle axis, depending on the thickness of the blank or the feed rate. Alternatively, as a second cutting scheme, the blank should be placed parallel on the machine table, and the nozzle axis should be inclined at the required angle relative to the blank's surface [10].

15. One of the features of the proposed new technological process for hydroabrasive cutting is the development of a new design for the water nozzle head to prevent the loss of pressure in the abrasive mixture. This design has been developed and applied in the research, making it possible to stabilize the pressure at which the water-abrasive jet is applied to the surface during hydroabrasive cutting.

16. The dissertation work was carried out based on a full factorial design of experiments, and mathematical equations were derived and interpreted using information technologies [14], [15].

17. The following results were obtained in the application of the new hydroabrasive cutting method of the cutting and forming details of the dies studied for stamping weapons parts of the manufacturing enterprise, based on the results of the dissertation work:

-the machining accuracy and dimensional deviations are $0,01 \div 0,06 \text{ mm}$, which is $2 \div 2,5$ times higher than the indicators of existing technological processes;

- due to the reduction in the machining share, a conditional saving of 1,5 kg per stamp is achieved on average;
- the quality of the machined surface improves by 30-35%, eliminating the need for additional technological processes;
- the service life of the stamp increases by 15-20 %;
- productivity increases by 25 %.

Considering these results, the conditional economic benefit from the application of the new hydroabrasive technological process in the production of 100 stamps is 40000 AZN.

The List of Published Works on the Dissertation Topic

1. Амиров, Ф.Г. Определение точности измерений при обработке давлением воды с использованием 3D-сканирования/Ф.Г.Амиров, С.Симон, С.Ф.Амирли [и др.] // Herald of the Azerbaijan Engineering Academy, – Баку: – 2021.Vol.13. no.3. – pp. 38-44.

2. Simon S., Yusubov N.D., Amirli S.F. Formation of Geometric Parameters of the Surfaces of Cylindrical Parts during Waterjet Cutting // Advances in Science and Technology Submitted.- 2024, Vol.148, -pp. 59-64.

3. Simon S. The influence of cutting regime parameters on surface roughness in hydroabrasive waterjet processing of HARDOX-500 material / S.Simon, N.D. Yusubov, S.F.Amirli [and others] // Materials Of The VI International Scientific Practical Conference «Energy and Resource Saving Technologies: Experiences and Prospects» – Кызылорда: – 2024. – pp. 179-187.

4. Simon S. Research on some issues of the processed surface formation in the hydroabrasive cutting of chrome-nickel steels / S.Simon, N.D.Yusubov, S.F. Amirli [and others] // International Symposium on Unmanned Systems: AI, Design, and Efficiency held in Baku, Azerbaijan on 22nd of May and 24th of May. – Baku: – 2024, – p. 26.

5. Симон, С. Некоторые особенности стружкообразования при гидроабразивной обработке./ С.Симон, Н.Д.Юсубов, С.Ф. Амирли, [и др.] // Известия высших учебных заведений. Машиностроение, – 2024. № 11, – с. 53-61.

6. Симон, С., Юсубов, Н.Д., Амирли, С.Ф. Исследование микротвёрдости при гидроабразивной отрезке заготовок из стали HARDOX–500//Профессиональные коммуникации в научной среде – фактор обеспечения качества исследований: материалы XIII Всероссийской научно-практической конференции /под ред. Р. С. Шамсутдинова [и др.]; Альметьевский филиал Казанского национального исследовательского технического университета им. А.Н. Туполева – КАИ. – Санкт-Петербург: – Сциентиа, – 2024. –Том XIII, – с.16-21.

7. Simon, S. Hidroabraziv emalin gəmiqayırmada tətbiqi / S.Simon, N.D. Yusubov, S.F. Əmirli // Azərbaycan Dövlət Dəniz Akademiyasının Elmi Əsərləri, – Bakı: – 2024. №1, – s. 47-52.

8. Simon S., Yusubov N.D., Amirli S.F. Müxtəlif kəsmə rejimlərində xrom-nikel tərkibli hardox–500 materialından kəsilən pəstahların mikrobərkliyinin araşdırılması // “Mütərəqqi texnologiyalar və innovasiyalar” mövzusunda IX Respublika elmi-texniki konfransı,- Bakı, AzTU:-1-2 may,-2024.-s.439-443.

9. Амирли С.Ф. Точность изготовления деталей сложного профиля из хромо-никелевых сплавов хардох-500// XII Международной научно-практической конференции «Современные проблемы теории машин»,-Санкт-Петербург:- 31 мая, 2024 г. – №17,- с. 147-149.

10. Симон С., Юсубов Н.Д., Амирли С.Ф., Амиров Ф.Г. Технологические особенности отрезки заготовки HARDOX-500 гидроабразивным способом// Вестник машиностроения. -2024. Т. 103. № 9. -с.781-785.

11. Simon, S. Hardox-500 markalı xrom-nikel poladının hidroabrazivlə emalında mikrobərkliyin kəsmə rejimlərindən asılılığının tədqiqi / S.Simon, N.D. Yusubov, S.F. Əmirli, və b. //

Azərbaycan Mühəndislik Akademiyasının Xəbərləri, – Bakı: – 2024. cild 16, № 4, – s.27-33.

12. Simon S., Yusubov N.D., Amirli S.F., Amirov F.G. Waterjet Cutting of HARDOX-500 Workpiece. Russian engineering research.-2024. Vol. 44 No. 11. -pp.1572-1576.

13. Simon S., Yusubov N.D., Amirli S.F. Investigation of the variation in surface microhardness depending on longitudinal feed in the processing of HARDOX-500 chromium-nickel steel by various methods/VI International Turkic World Congress on science and engineering.- Baku:-19-21 December 2024. - p.328.

14. Simon S. Planning of Full Factorial Experiments for the Investigation of Roughness in Hydroabrasive Waterjet Cutting of Hardox-500 Steel / S.Simon, N.D.Yusubov, S.F. Amirli [and others] // Pakistan Journal of Life and Social Sciences. –Pakistan: –2024, 22(2). – pp. 21590-21595.

15.Симон, С. Исследование параметра шероховатости поверхности хромоникелевой стали после гидроабразивной обработки с применением полного факторного эксперимента / С. Симон, Н.Д. Юсубов, С.Ф. Амирли, [и др.] // Вестник машиностроения. –2025. Т. 103. № 1, – с. 60-64.

The candidate's personal contribution to the published scientific works:

The work referenced as [9] was carried out independently by the author.

In works [1-8, 10-15], the formulation and solution of the problem, conducting experimental research, processing the results, providing recommendations, and the formulation of scientific propositions were carried out by the author, while the remaining sections were completed in collaboration with co-authors.

The dissertation defense will be held on 20 october 2025 at 11⁰⁰ during a session of the BFD 2.09/2 Dissertation Council operating under the Azerbaijan Technical University.

Address: AZ 1073, H. Javid Avenue 25, Baku, Azerbaijan Technical University, Room 317

The dissertation is available for review at the library of Azerbaijan Technical University.

The electronic versions of the dissertation and the abstract have been made available on the official website of Azerbaijan Technical University.

The abstract was sent to the required addresses on 19 september
2025. 

Signed for print: 18.10.2025
Paper format: A5
Volume: 47.205
Print run: 100